

Select the film speed by turning the **FILM-SPEED DIAL**. Notice that this moves a pair of masks in front of the CdS photocell. The faster the film speed selected, the larger the aperture between the masks.

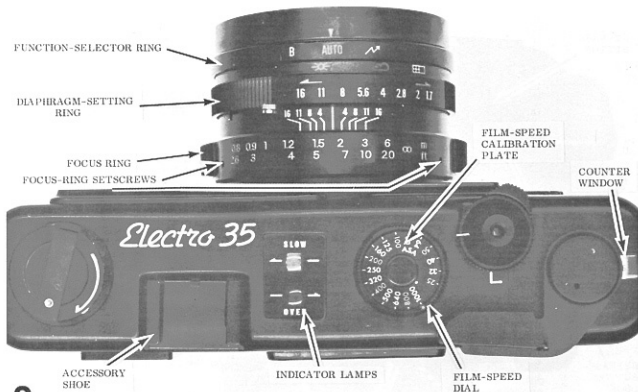

2

The FUNCTION-SELECTOR RING has three positions: "B" (for bulb), a lightning-flash symbol (for using flash), and "AUTO." At the "AUTO" position, the shutter-speed control is fully automatic.

Selecting the diaphragm setting moves the diaphragm leaves to the desired *f*/stop. At the same time, the diaphragm-setting ring selects a value of resistance for the exposure-control circuit. The shutter then automatically programs the shutter speed according to the amount of light striking the CdS cell, the diaphragm setting, and the film-speed setting.

The fastest speed the camera can deliver is 1/500 second. As you start depressing the release button, watch the indicator lamps on the top cover. If the red (overexposure) lamp comes on, you know that the fastest shutter speed of 1/500 second is too slow for the proper exposure. You must then set a smaller *f*/stop.

If the yellow (slow) lamp comes on, the required shutter speed is too slow for a hand-held exposure (slower than 1/30 second). The yellow-lamp warning tells you to use a larger *f*/stop, a flash attachment, or a tripod.

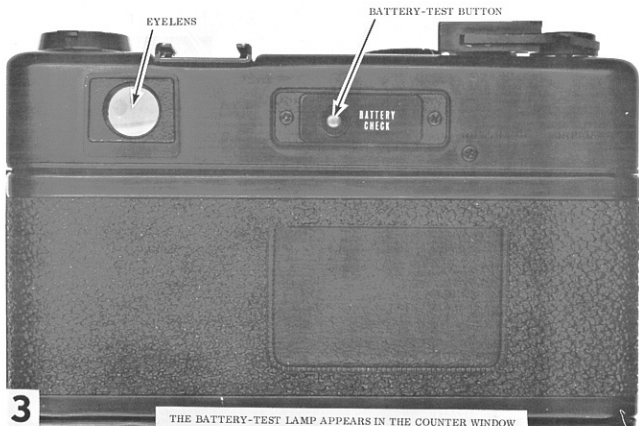

3

THE BATTERY-TEST LAMP APPEARS IN THE COUNTER WINDOW

You'll find the battery-test lamp in one of two positions, according to the camera model. In current models, the battery-test lamp appears in the counter window when you depress the battery-test button. Here, the battery-test lamp serves a second function -- it illuminates the counter dial, making the calibrations visible at night. In earlier models, the battery-test lamp is next to the battery-test button, Fig. 4.

VARIATION (EARLIER MODEL)

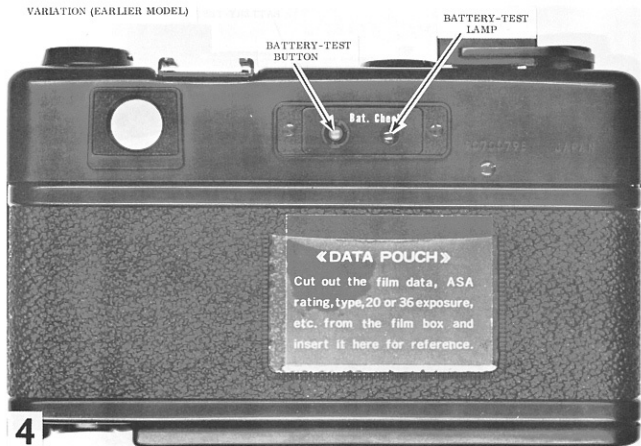

FLASH
TERMINAL

IN LATER MODELS,
OPEN THE BACK BY
PULLING UP THE
REWIND KNOB

BACK LATCH IN
EARLY MODEL

5

«DATA POUCH»

Cut out the film data, ASA
rating, type, 20 or 36 exposures,
etc. from the film box and
insert it here for reference.



1. UNSCREW BATTERY COVER AND REMOVE THE 5.2-VOLT BATTERY (MALLORY TR164, EVEREADY E164, OR EQUIVALENT)

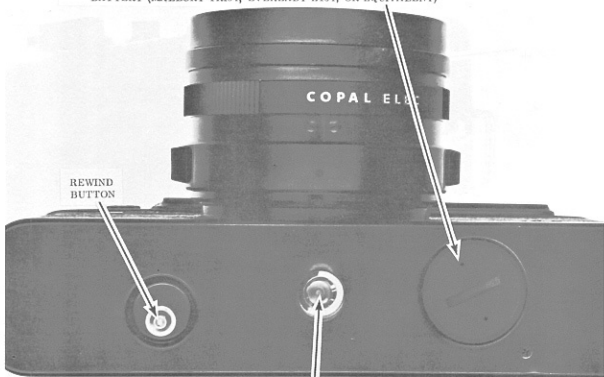

REWIND
BUTTON

TRIPOD
SOCKET

2. REMOVE THREE SCREWS AND LIFT OFF BOTTOM PLATE

6

Removing the bottom plate in earlier models requires some manipulation to clear the back latch.

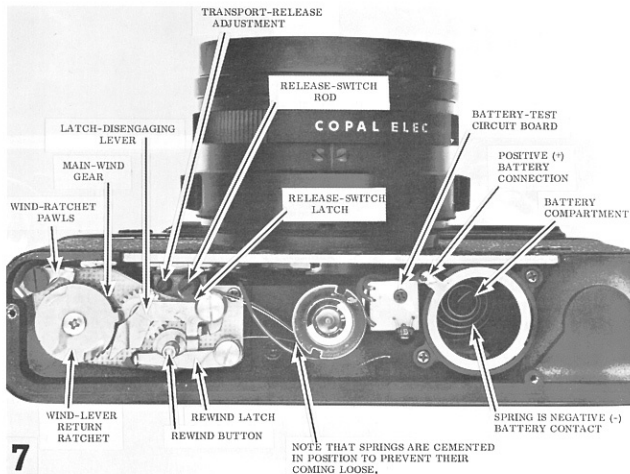

The transport-release adjustment is accessible from the bottom of the camera. Yet you can make the same adjustment from the top of the camera after removing the top cover plate. This adjustment will be described later, when the parts controlled by the adjustment are visible.

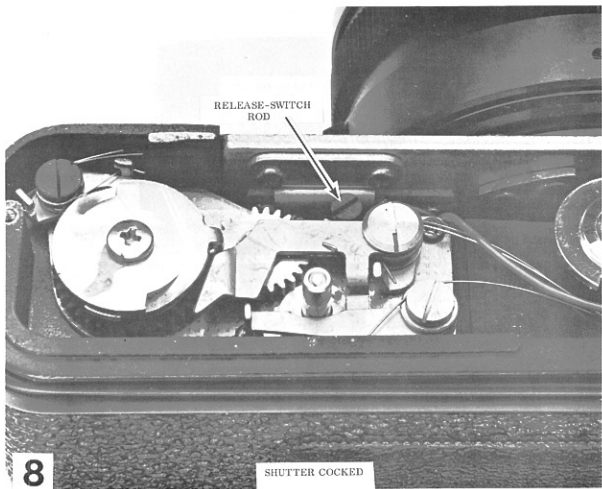

RELEASE-SWITCH
ROD

8

SHUTTER COCKED

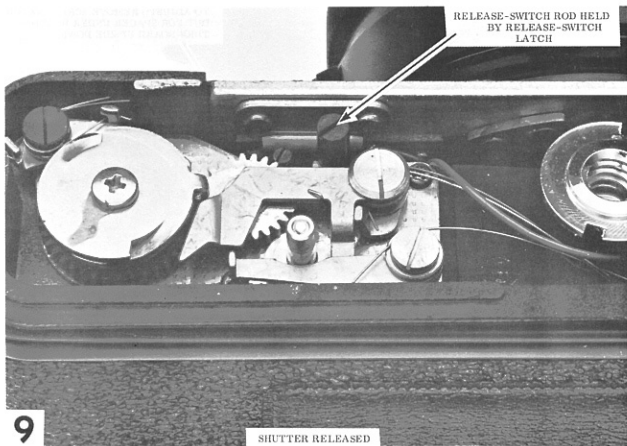

Notice that the end of the release-switch rod moves toward the bottom of the camera as you depress the release button. The release-switch latch then drops into a groove in the release-switch rod -- that holds the release-switch rod in the depressed position until you cock the shutter for the next exposure. This latching arrangement assures that the exposure-control circuit remains connected -- even though you allow the release button to return to its rest position.

Turning the screwdriver-slotted end of the release-switch rod controls the point at which the release-switch latch drops into engagement. Check to see that the release-switch latch engages the slot in the release-switch rod at the same moment that the shutter releases. The adjustment may be disturbed when you replace the front plate of the camera.

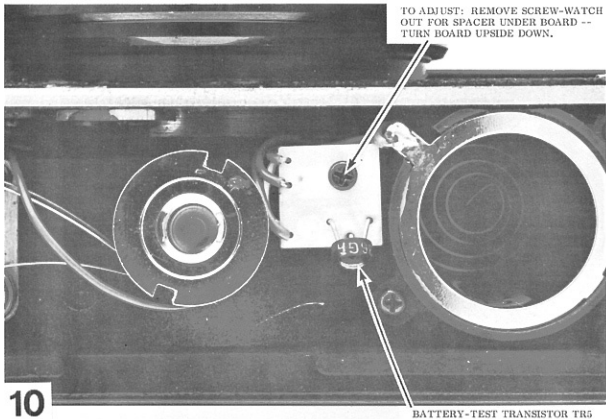

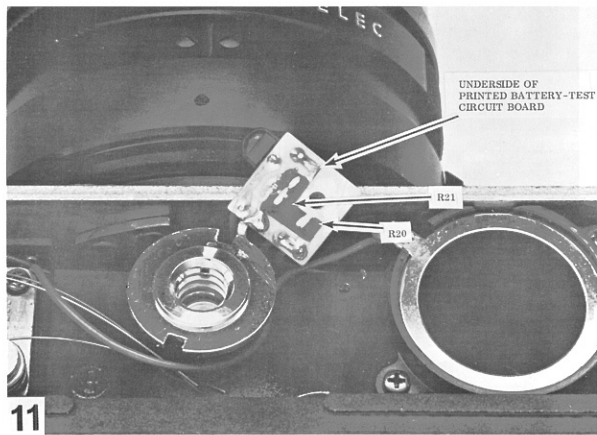

The battery-test lamp should turn on with 3.9 volts supplied to the battery terminals; it should turn off with 3.5 volts supplied. Adjustment in the earlier models (figure 12) is by changing the values of the fixed resistors; adjustment in the current models is by scratching the surface of the printed resistors to increase the resistance.

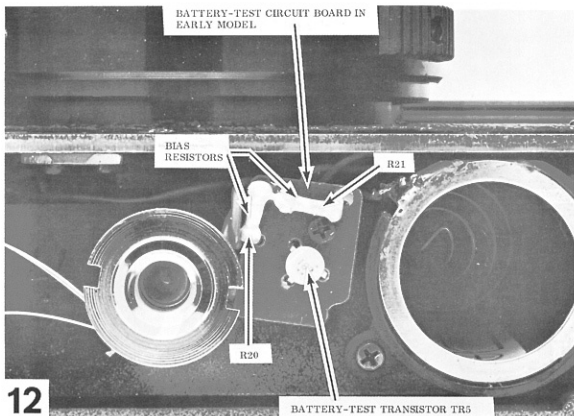



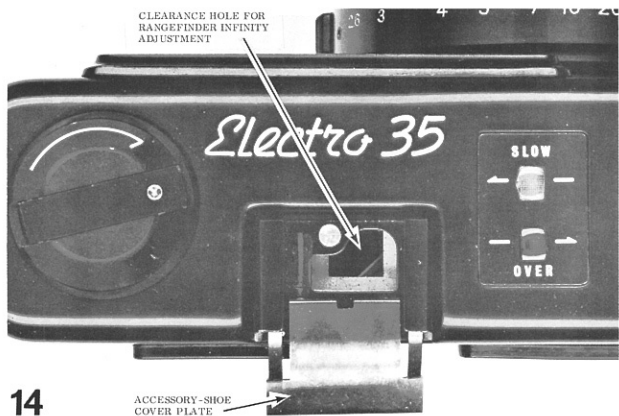

You can reach the rangefinder infinity adjustment without removing the top cover plate. Just lift the edge of the accessory-shoe cover plate that faces the front of the camera -- then, slide the accessory-shoe cover plate toward the back of the camera. You can now see the clearance hole for the infinity adjustment.

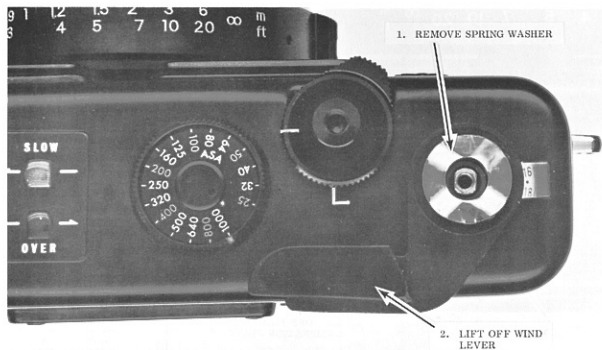

15

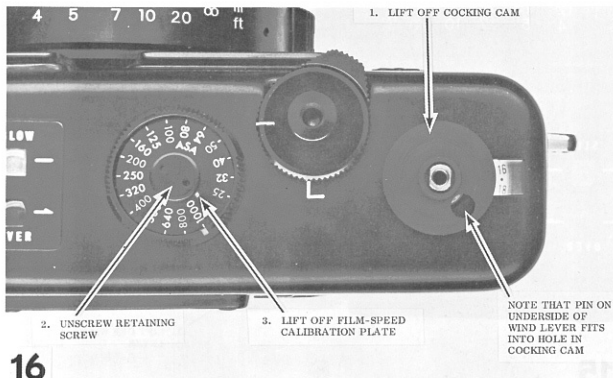

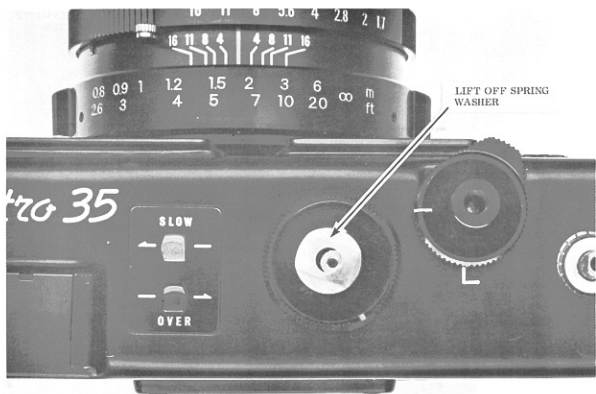

17

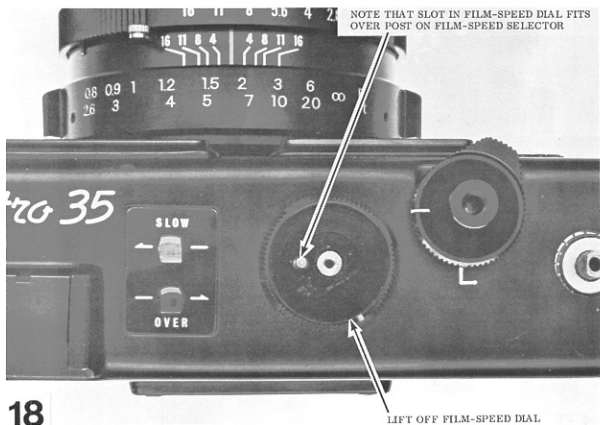

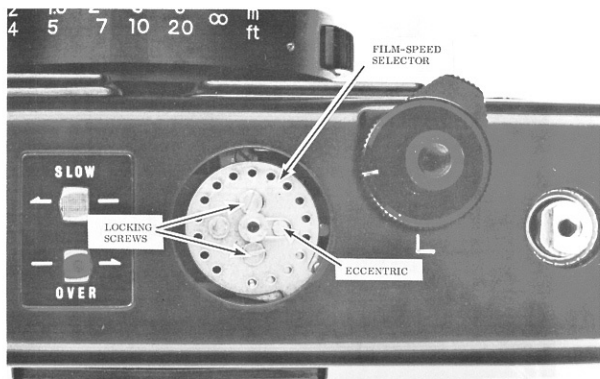

19

Removing the film-speed dial exposes one of the exposure adjustment points. By loosening the two locking screws on the film-speed selector, you can turn the eccentric. This adjustment changes the size of the opening between the two masks over the photocell. The range of adjustment possible is around $1/3 f/stop$.

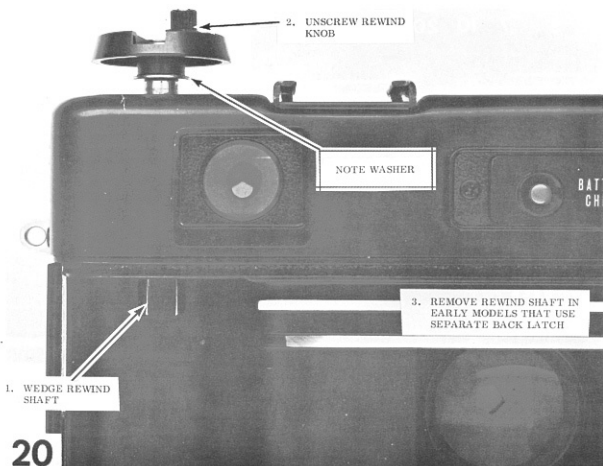

1. REMOVE TWO SCREWS

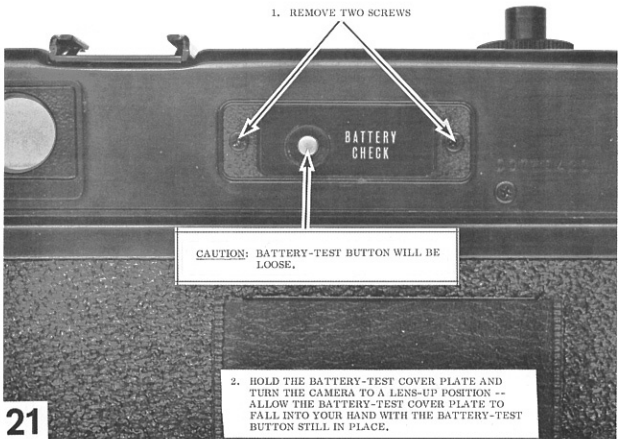

CAUTION: BATTERY-TEST BUTTON WILL BE LOOSE.

2. HOLD THE BATTERY-TEST COVER PLATE AND TURN THE CAMERA TO A LENS-UP POSITION -- ALLOW THE BATTERY-TEST COVER PLATE TO FALL INTO YOUR HAND WITH THE BATTERY-TEST BUTTON STILL IN PLACE.

21

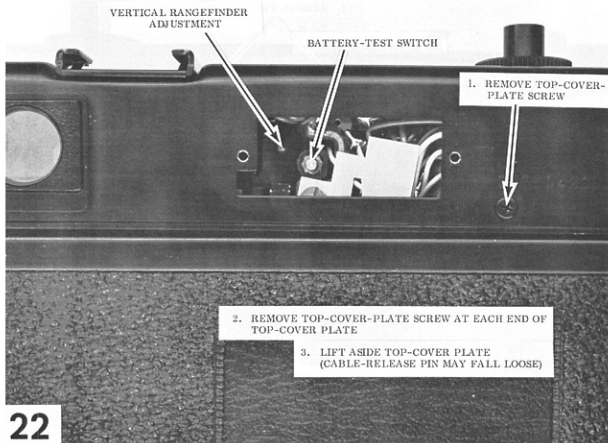

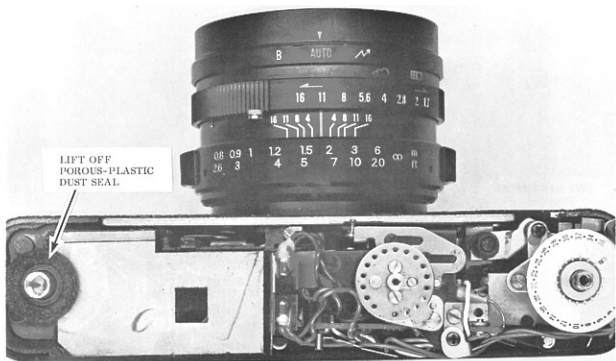

23

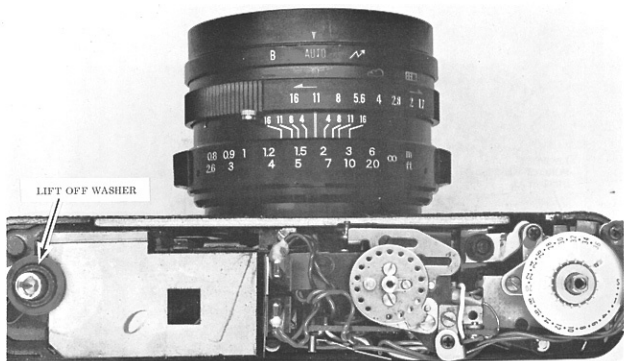

24

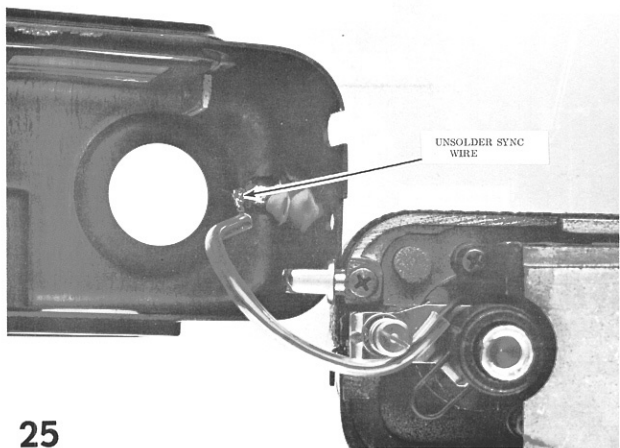

25

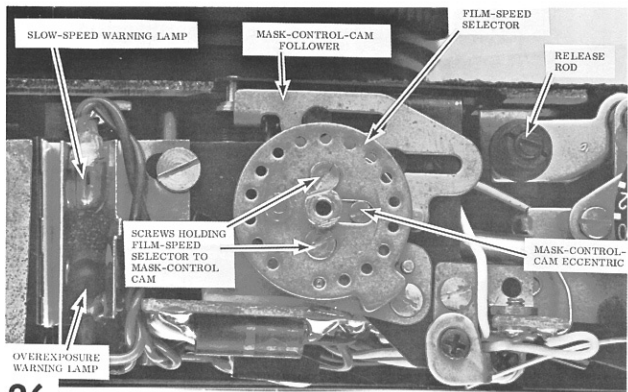

26

FILM-SPEED SELECTOR SET AT FASTEST FILM SPEED

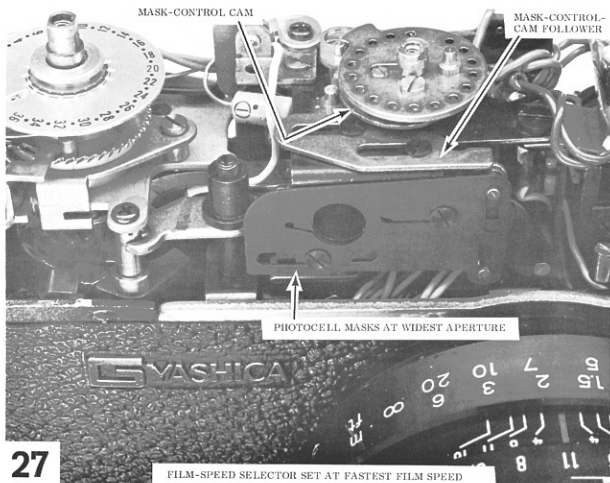

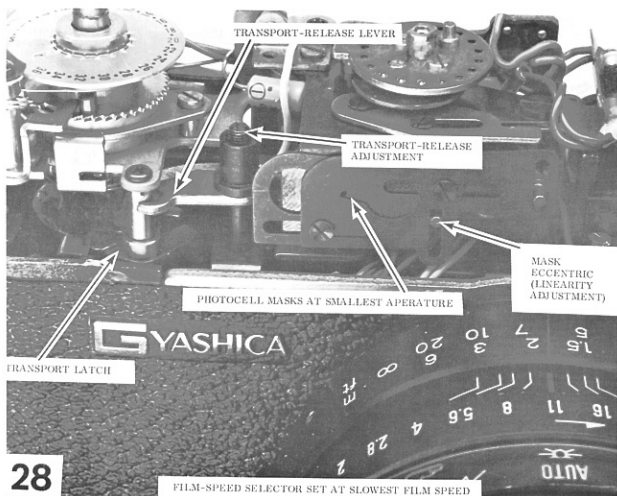

As you depress the release button, the transport-release lever pushes down the transport latch. The transport-release lever should push the transport latch out of engagement with the transport cam just before the shutter releases.

You can make the transport-release adjustment at either one of two places -- at the top of the release rod or at the bottom. (Figure 28 or Figure 7.) Both screwdriver-slotted adjustments affect the position of the transport-release lever. And the position of the transport-release lever determines the point at which the transport latch disengages during the downward stroke of the release rod.

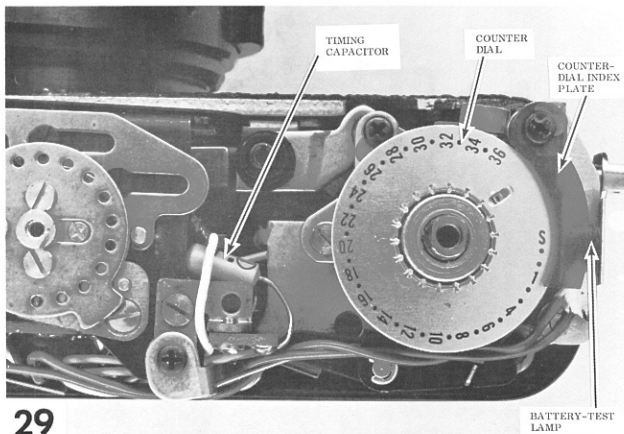

BATTERY-TEST-LAMP
WIRES SHIELD IN
LATER MODELS

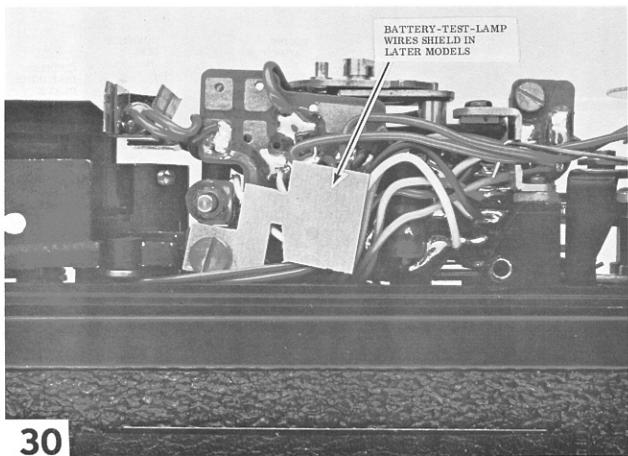

30

BATTERY-TEST
LAMP IN
EARLY MODEL

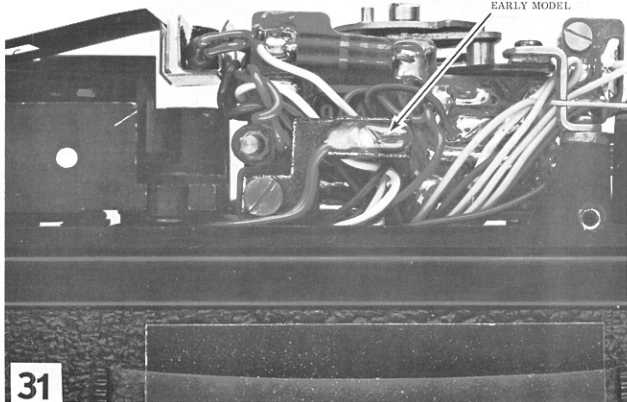

31

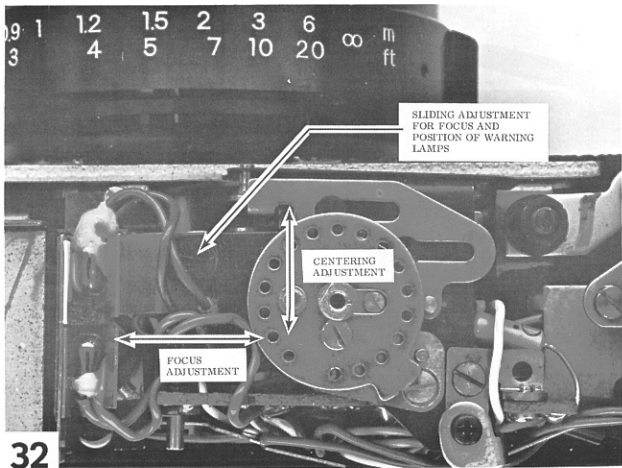

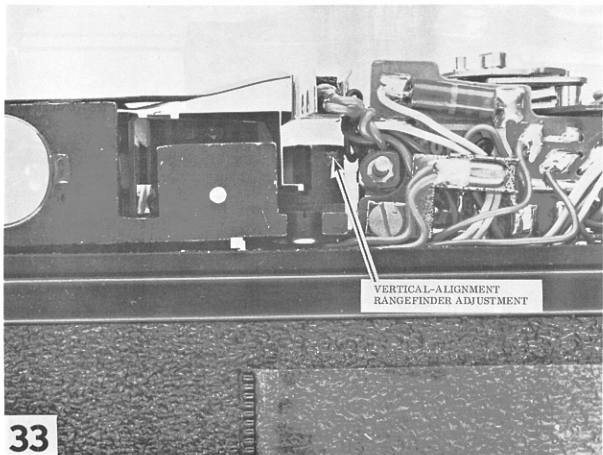

VERTICAL-ALIGNMENT
RANGEFINDER ADJUSTMENT

33

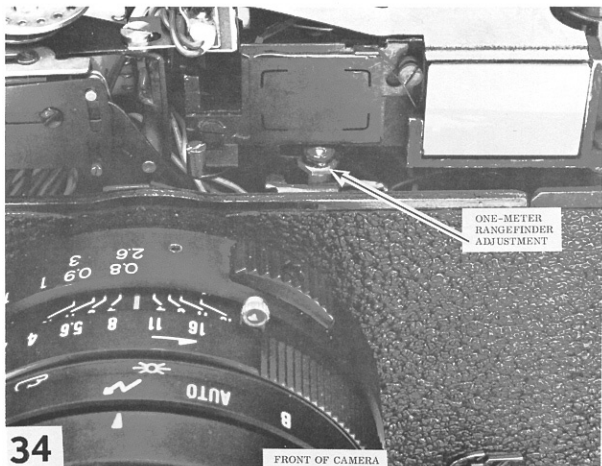

PEEL OFF RANGEFINDER
COVER PLATE

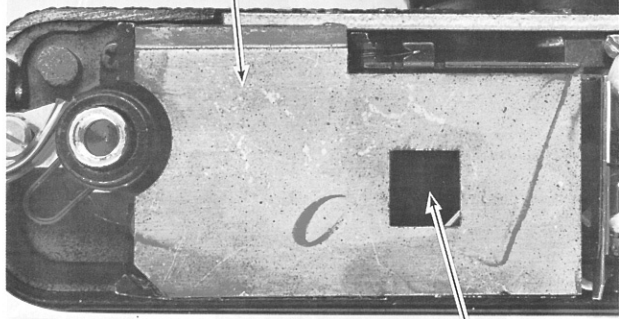

35

INFINITY ADJUSTMENT

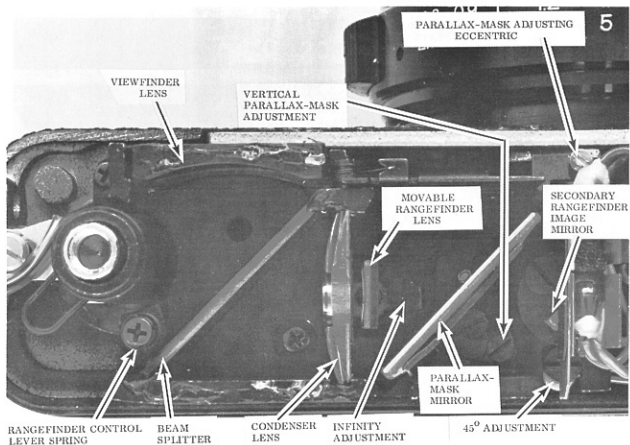

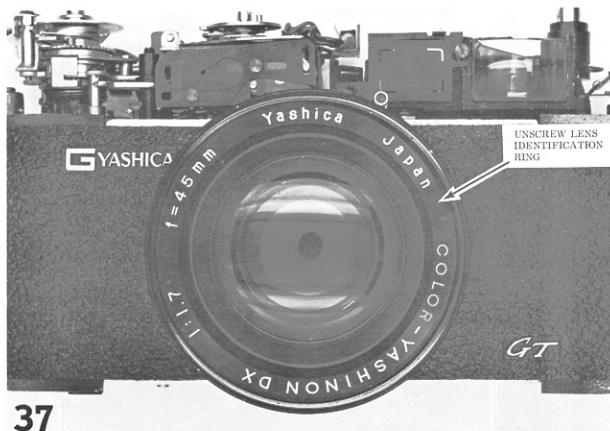

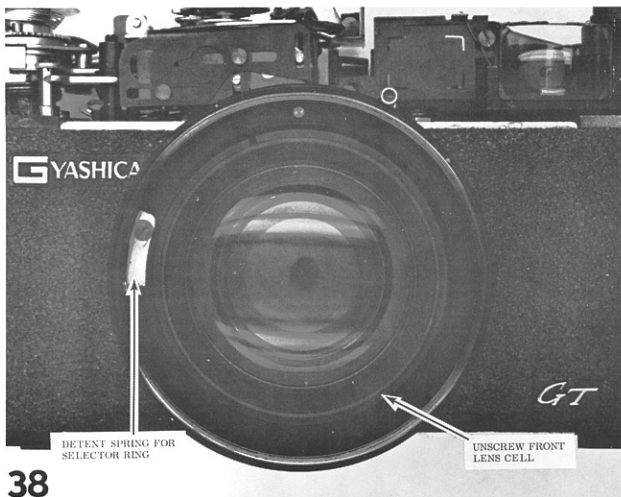

38

REMOVE THREE SCREWS AND LIFT OFF
SELECTOR-RING ASSEMBLY

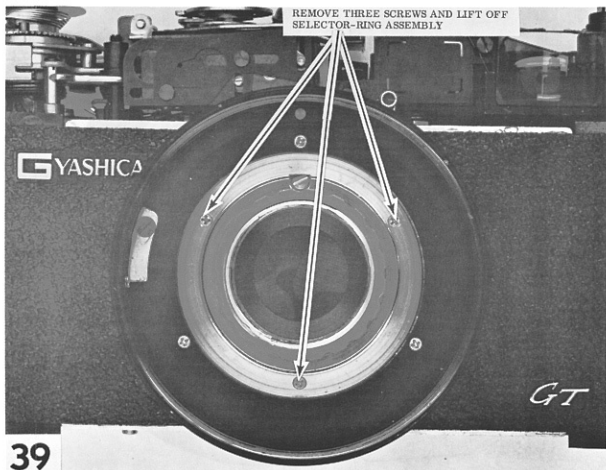

39

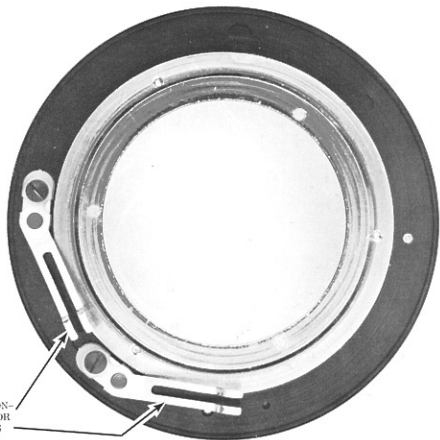

FUNCTION-
SELECTOR
BRUSHES

40

BACK OF SELECTOR-RING ASSEMBLY

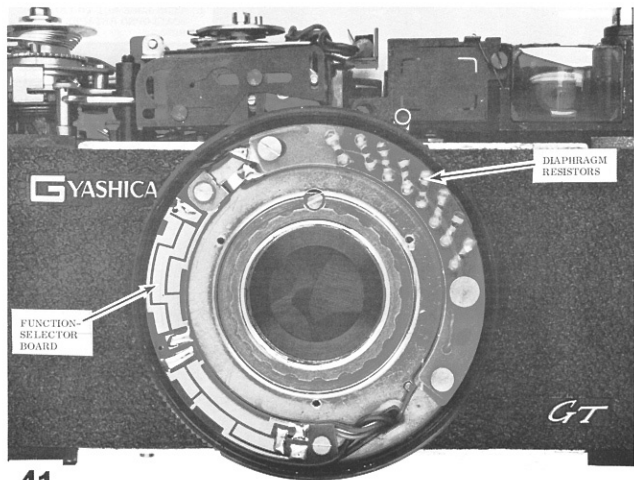

41

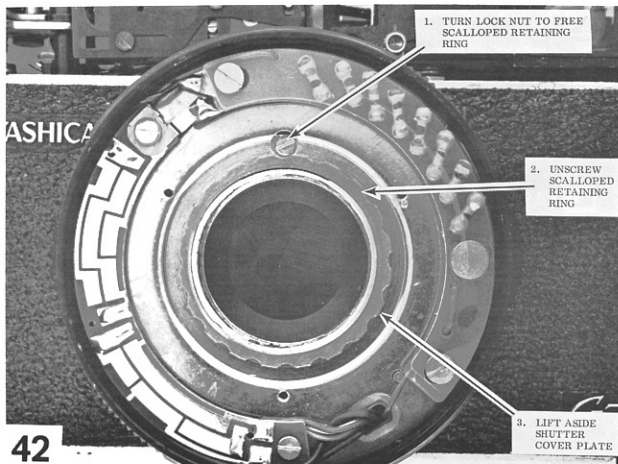

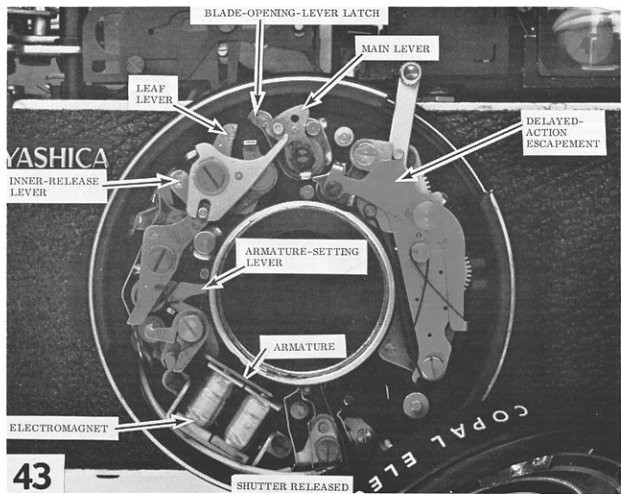

43

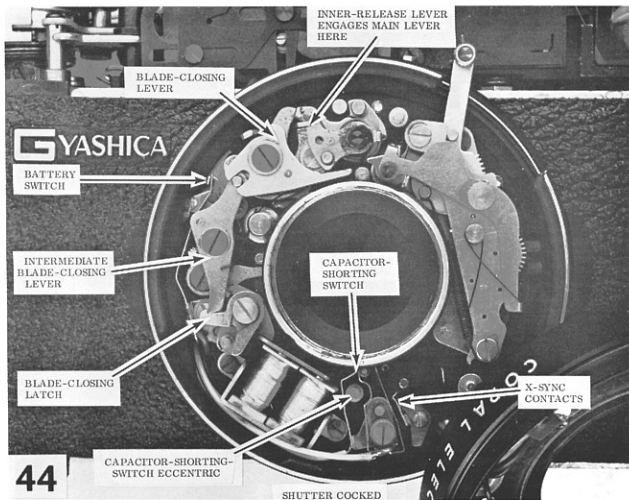

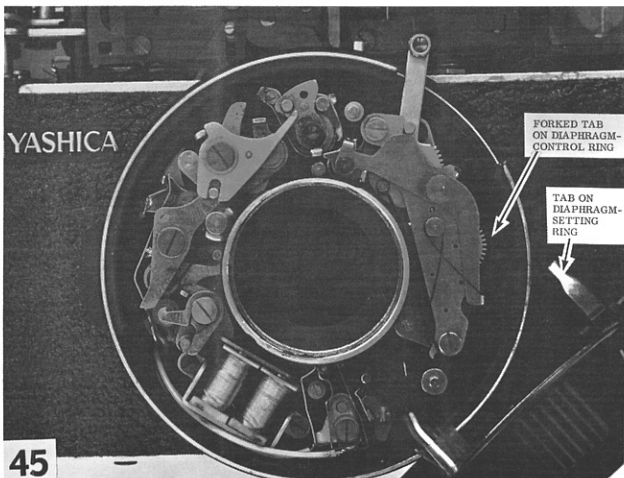

On reassembly, the tab on the diaphragm-setting ring must pass through the fork in the diaphragm-control ring. Turn both the diaphragm-setting ring and the diaphragm-control ring to one of their two extreme positions -- the smallest aperture or the largest aperture. To set the diaphragm-control ring to the largest aperture, turn its forked tab all the way clockwise.

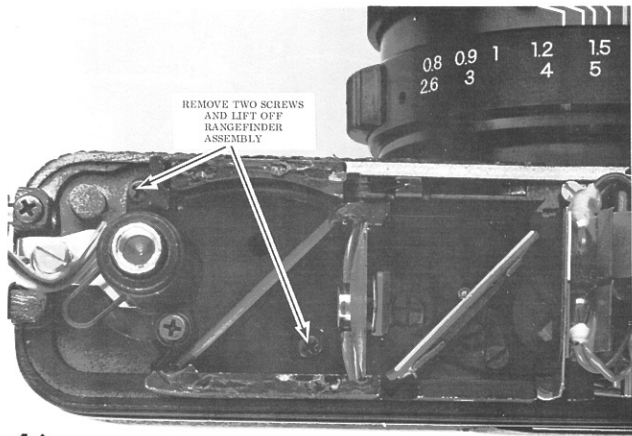

46

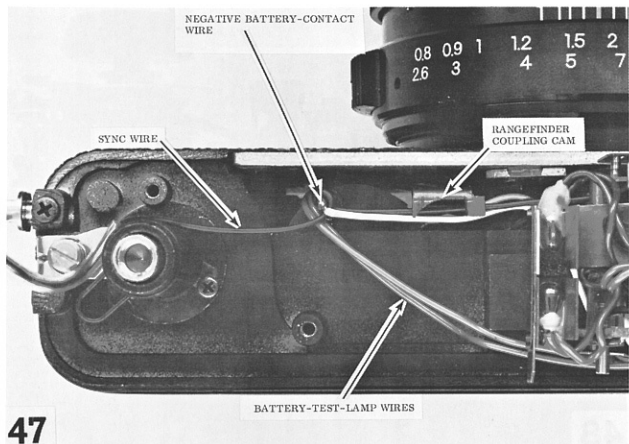



LOOSEN SCREW
AND REMOVE
SHIELD FOR
BATTERY-TEST-
LAMP WIRES

NOTE: IN EARLIER MODELS -- WITH BATTERY-TEST LAMP AT BACK
OF CONTROL MODULE -- LOOSEN SCREW AND SLIDE OUT
BATTERY-TEST LAMP

48

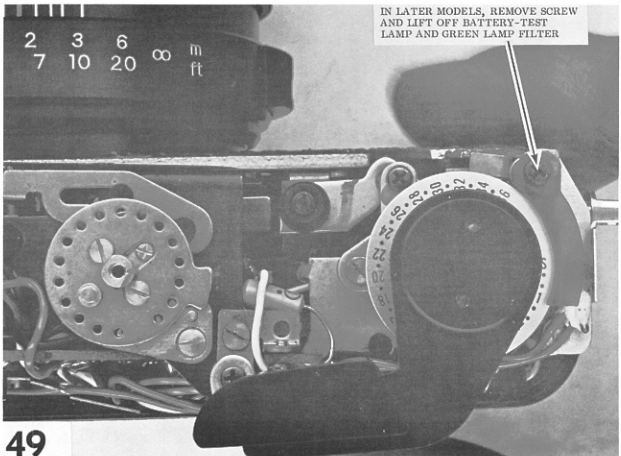

IN LATER MODELS, REMOVE SCREW
AND LIFT OFF BATTERY-TEST
LAMP AND GREEN LAMP FILTER

49

1. UNCOIL SYNC WIRE FROM
NEGATIVE BATTERY
TERMINAL

2. UNSOLDER WHITE WIRE FROM
NEGATIVE BATTERY TERMINAL

50

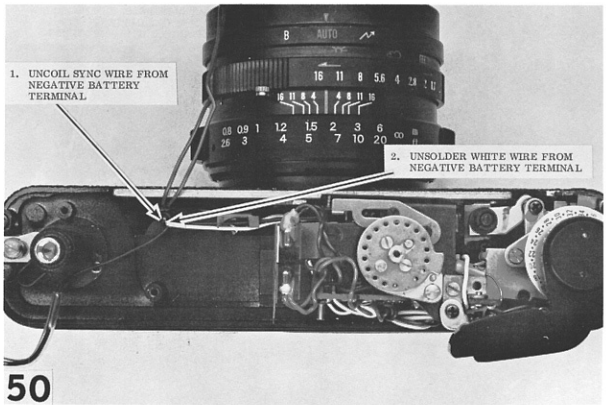

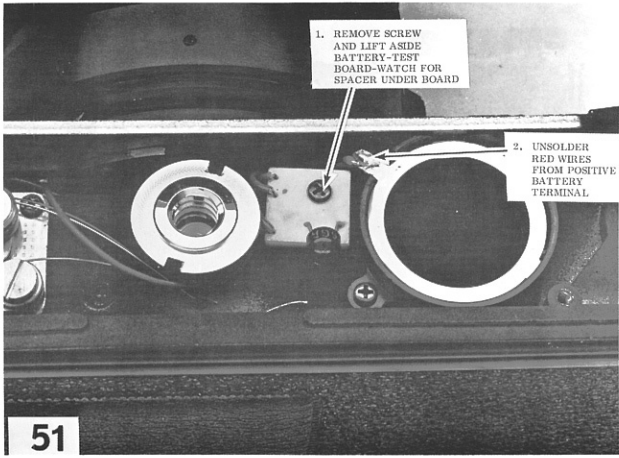

1. REMOVE SCREW
AND LIFT ASIDE
BATTERY-TEST
BOARD-WATCH FOR
SPACER UNDER BOARD

2. UNSOLDER
RED WIRES
FROM POSITIVE
BATTERY
TERMINAL

51

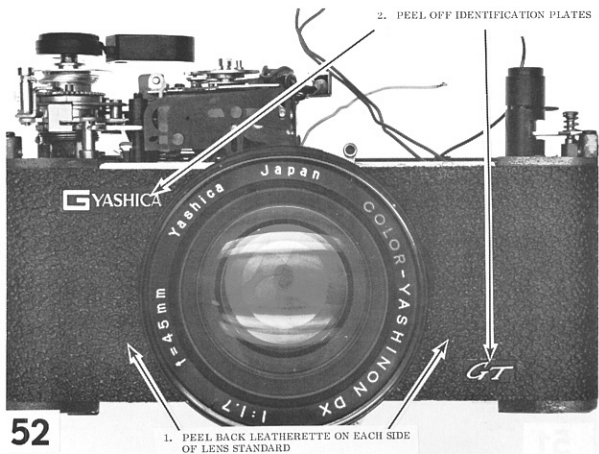

REMOVE FOUR FRONT-PLATE
SCREWS

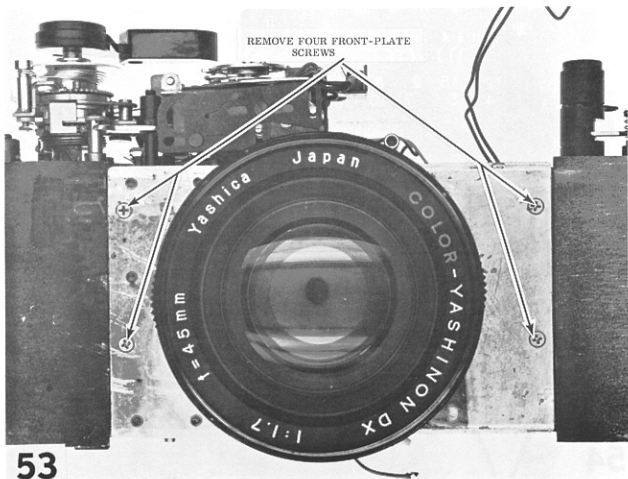

53

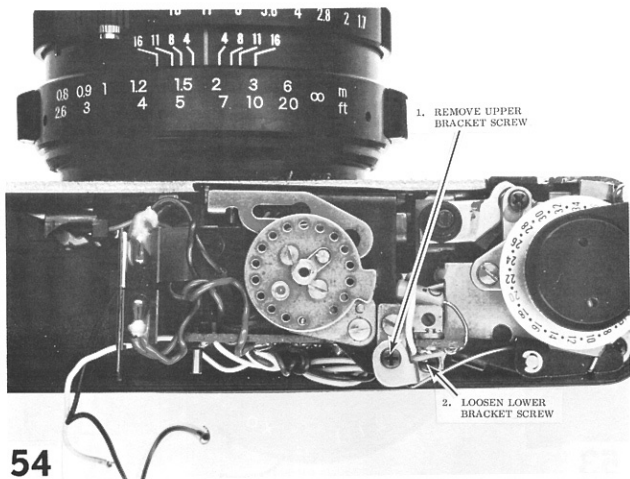

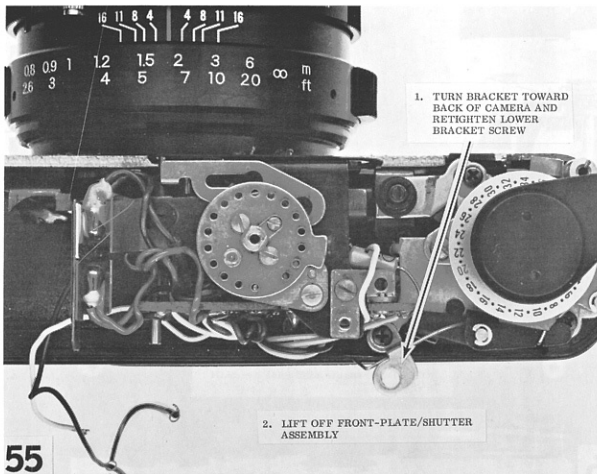

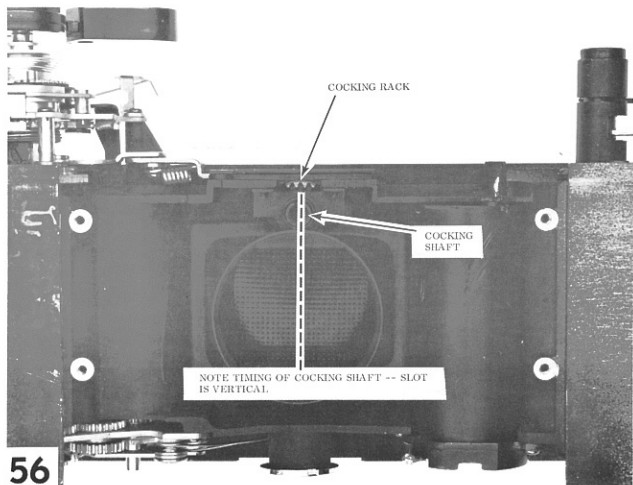

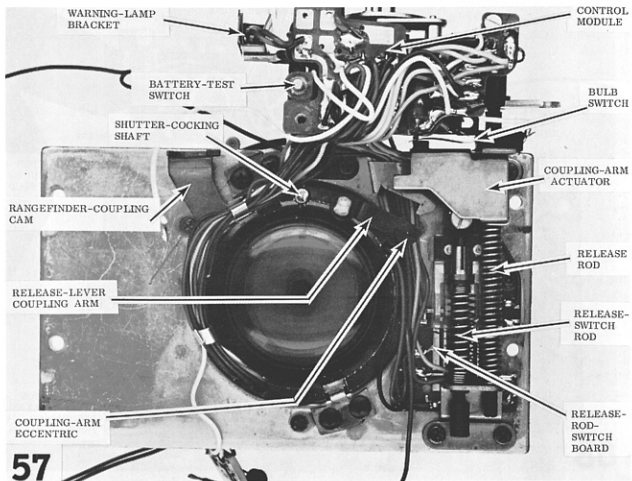

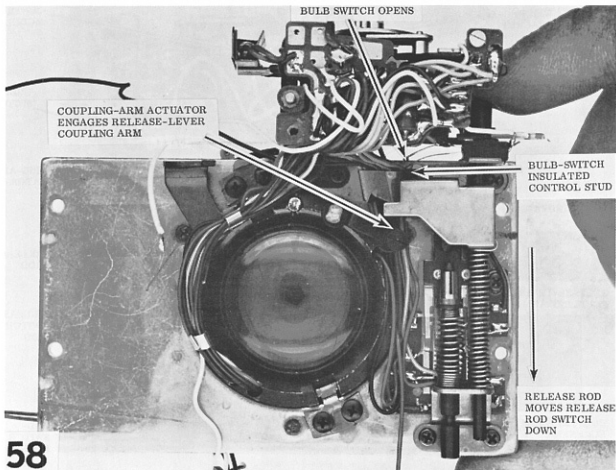

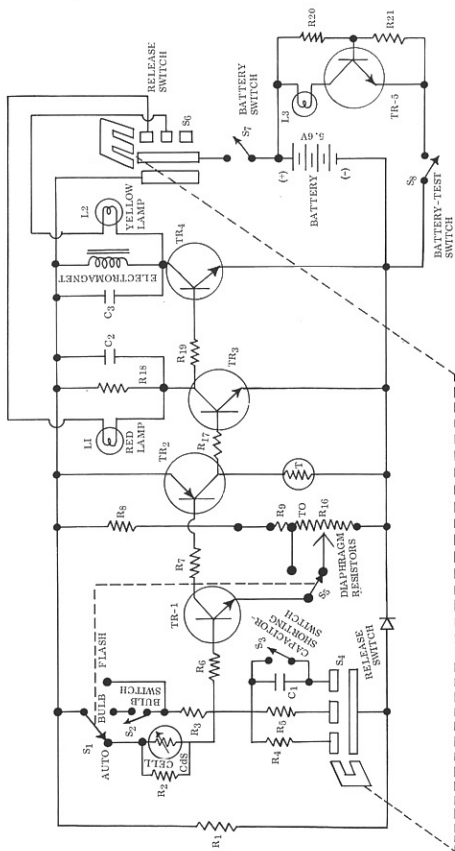

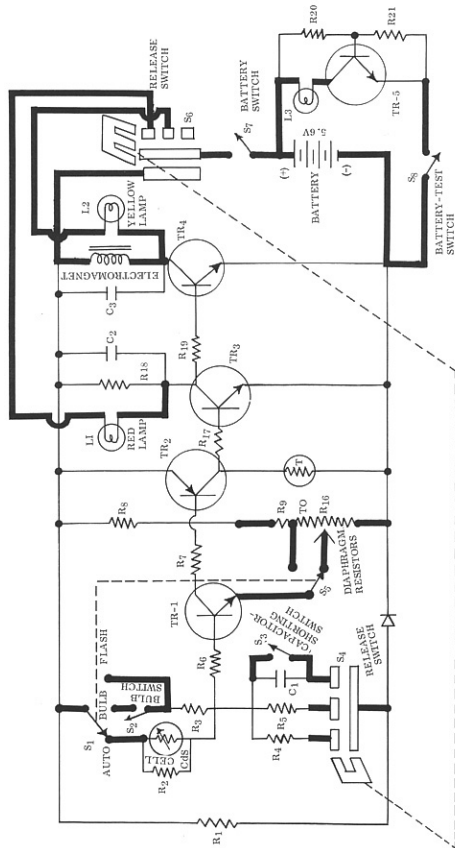

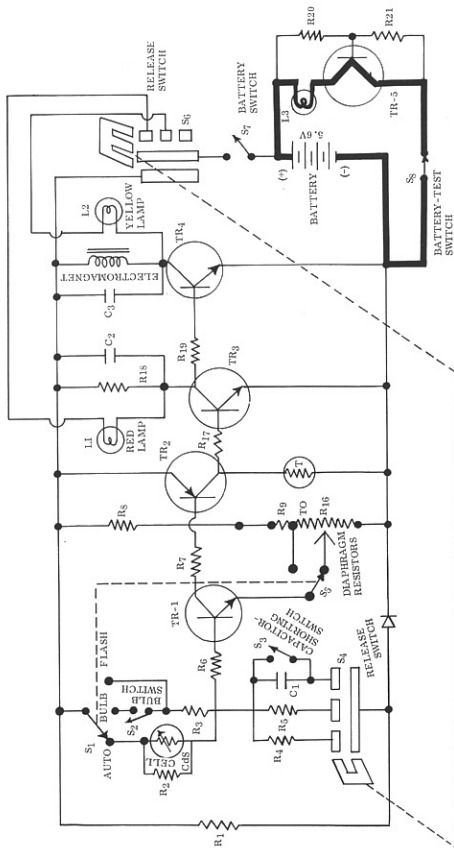

HEAVY LINES INDICATE CURRENT PATH FOR
BATTERY-TEST LAMP

Depressing the battery-test button closes the battery-test switch S₈. Battery current then flows through resistors R₂₁ and R₂₀. A sufficient voltage drop across R₂₁ turns on transistor TR₅. So current flows through the transistor and through the battery-test lamp L₃.

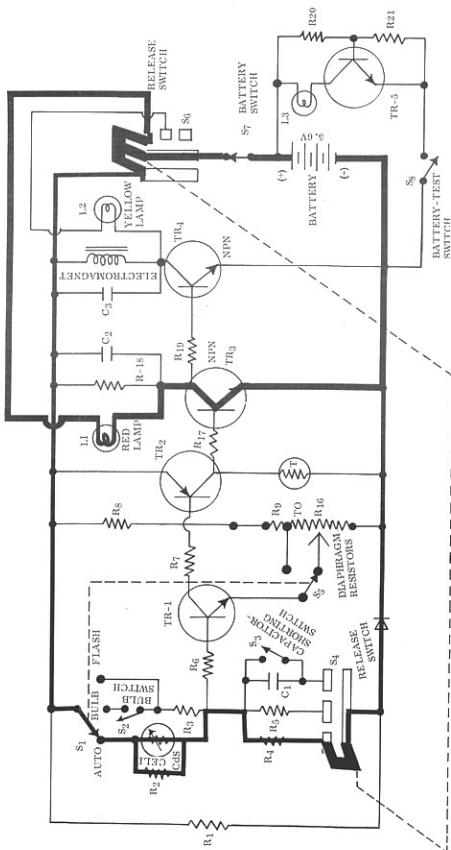

HEAVY LINES INDICATE CURRENT PATH FOR RED (OVEREXPOSURE) WARNING LAMP L₁

As you start depressing the release button, the shutter-release switch connects the red lamp L₁ into the circuit. But L₁ can turn on only if transistor TR₃ conducts. And the triggering of transistor TR₃ depends on the resistance of the CdS cell, as established by the light conditions.

Consider that the light conditions are so bright that a shutter speed faster than 1/500 second is required. The resistance of the CdS cell is then low. Consequently, enough of the battery voltage is dropped across resistor R₄ to trigger transistor TR₁. Transistor TR₁ triggers transistor TR₂. And TR₂ triggers TR₃ to turn on lamp L₁. You can turn off lamp L₁ by setting a smaller diaphragm opening -- that changes the resistance in the emitter circuit of TR₁.

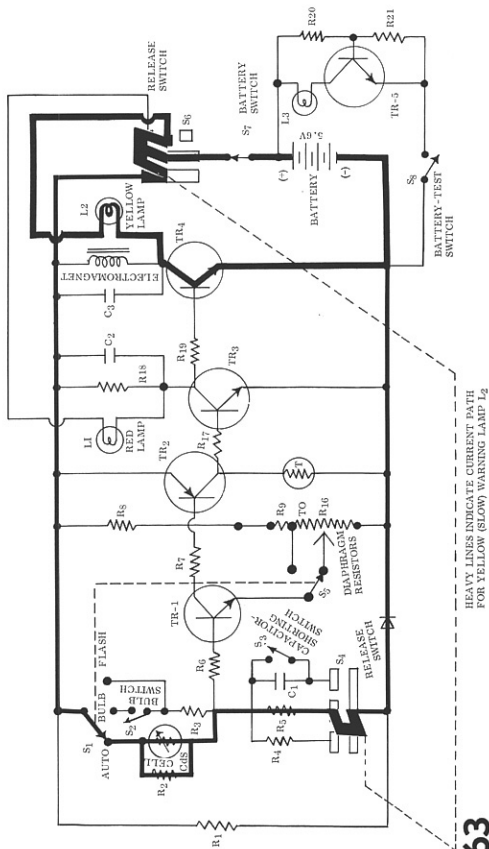

63

Depressing the release button a little further connects the yellow lamp L_2 . Lamp L_2 turns on when the light conditions are so dim that a shutter speed slower than 1/30 second is required. The resistance of the CdS cell is then high.

The high resistance of the CdS cell keeps transistor TR1 turned off -- the voltage dropped across R_5 is too low to trigger the transistor. Consequently, transistor TR2 and TR3 are also turned off. As long as transistor TR3 is turned off, transistor TR4 conducts. And the current flowing through transistor TR4 also flows through the yellow lamp L_2 .

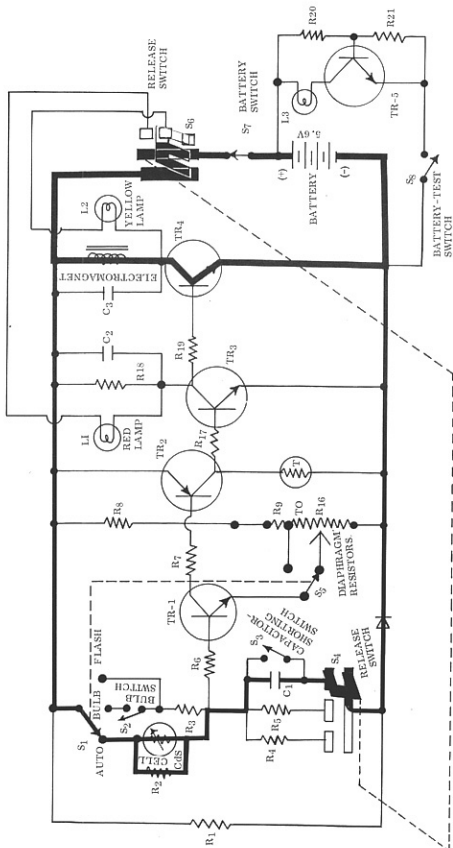

64

When the shutter-release switch reaches the bottom of its stroke, it connects the timing capacitor C_1 to the circuit. Also, the shutter releases and the blades move to the open position.

Transistor TR1 remains turned off while the timing capacitor charges to the required voltage. Consequently, transistor TR4 conducts current through the electromagnet.

The electromagnet holds its armature to keep the blades in the open position. The time it takes for the timing capacitor to charge depends on the resistance of the CdS cell. When the timing capacitor reaches a sufficient charge, the voltage on its positive plate turns on transistor TR1 -- this trigger voltage depends on the diaphragm setting which determines the resistance in the emitter circuit of TR1. TR1 turns on TR2, and TR2 turns on TR3. Now, TR3 robs transistor TR4 of the base current it needs to conduct. TR4 shuts off, depriving the electromagnet of current.

As the blades close, the blade-operating ring closes the capacitor-shortening switch S_3 . S_3 opens as the blades open and closes as the blades close. So the time that S_3 opens determines when the timing capacitor can start accepting a charge. The eccentric adjustment on S_3 is your high-speed adjustment point.

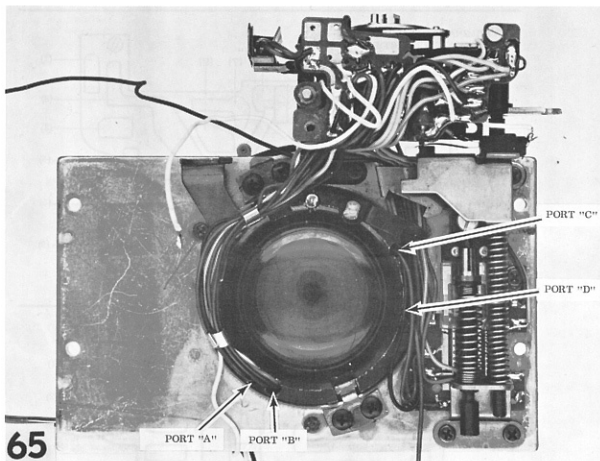

Note the color coding of the wires coming from each port. In different cameras, the color codes may vary slightly from port to port. But they're generally consistent from side to side.

Here's the normal color coding of the wires from each port:

PORT A -- green, dark blue, orange, and brown

PORT B -- red, white, and purple

PORT C -- yellow, yellow, red, and black

PORT D -- red, black, and brown

TERMINAL LOCATION FOR
PHOTOCELL CIRCUIT BOARD
TYPE 368

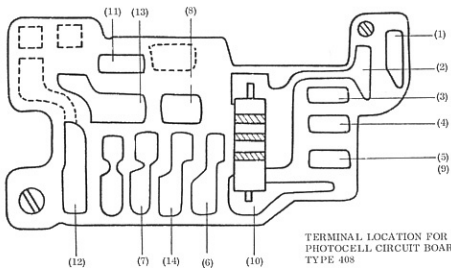
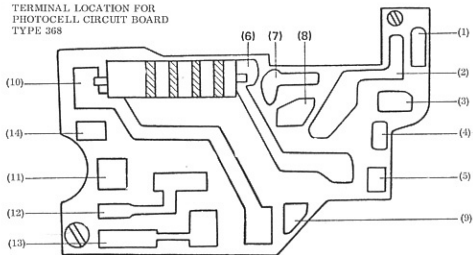

TERMINAL LOCATION FOR
PHOTOCELL CIRCUIT BOARD
TYPE 408

TO REMOVE CONTROL MODULE:
UNSOLDER WIRES FROM BACK OF
CONTROL MODULE

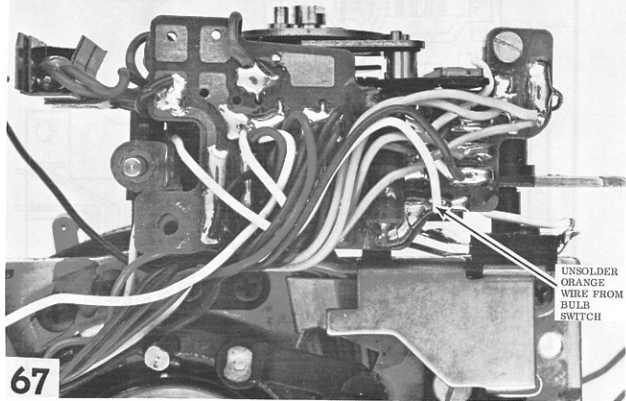

UNSOLDER
ORANGE
WIRE FROM
BULB
SWITCH

67

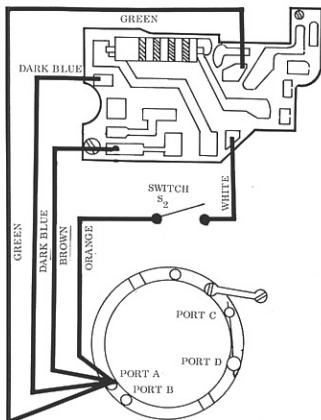

WIRING FROM PORT A

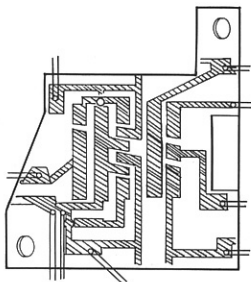

68

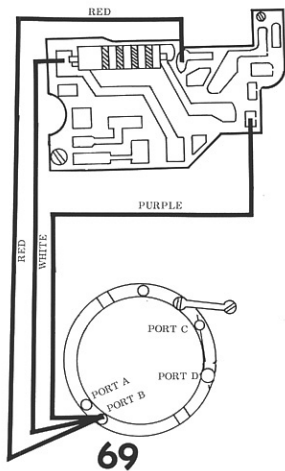

WIRING FROM PORT B

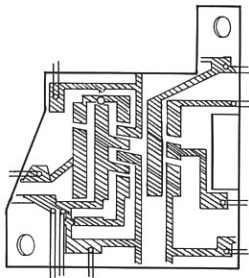

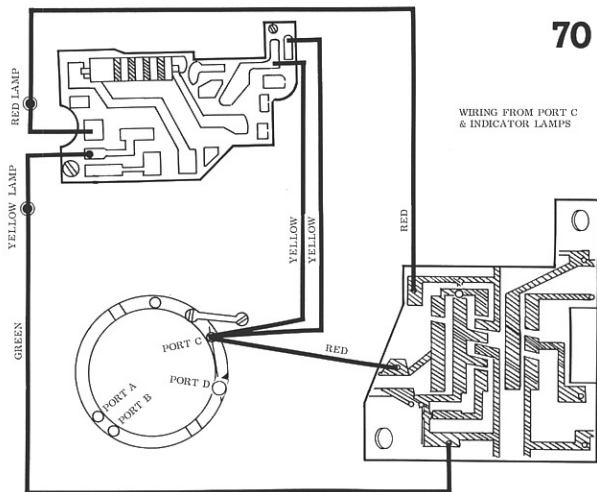

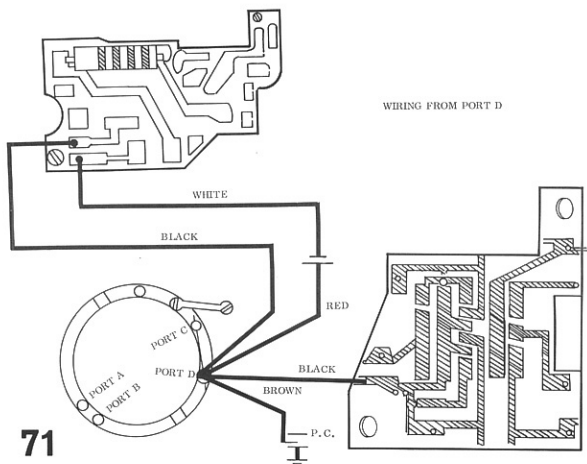

71

DIRECT WIRING OF SWITCH BASE PLATE TO PHOTOCELL ASSEMBLY

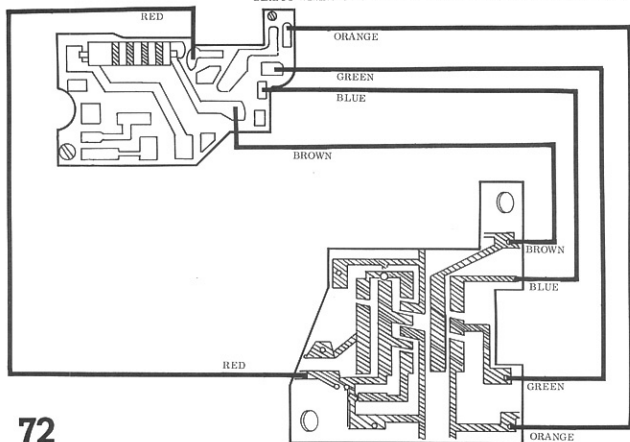

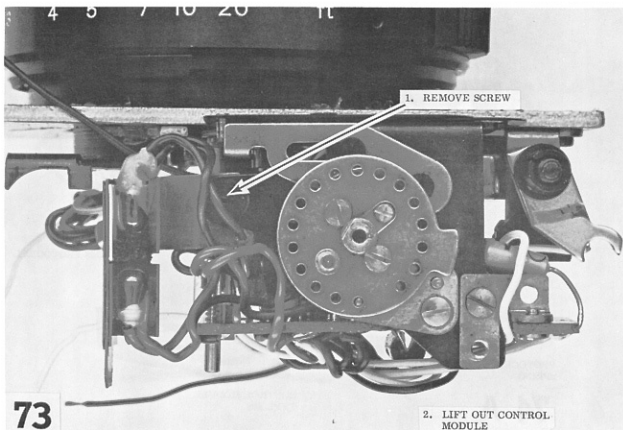

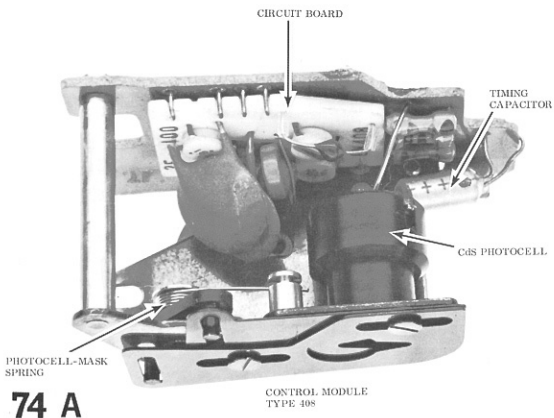

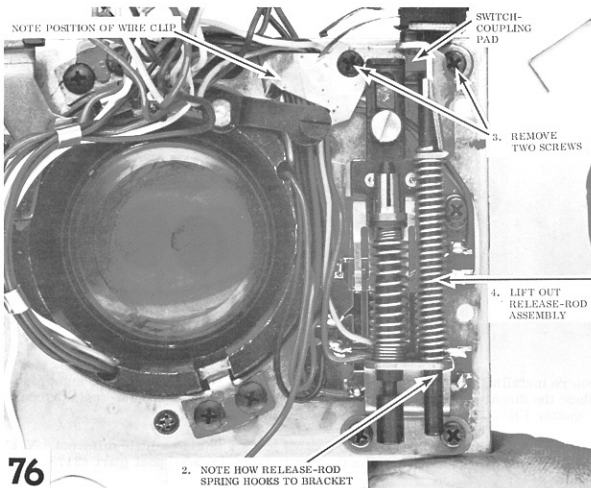

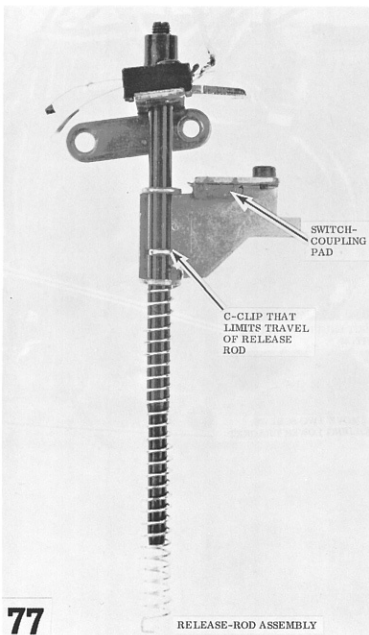

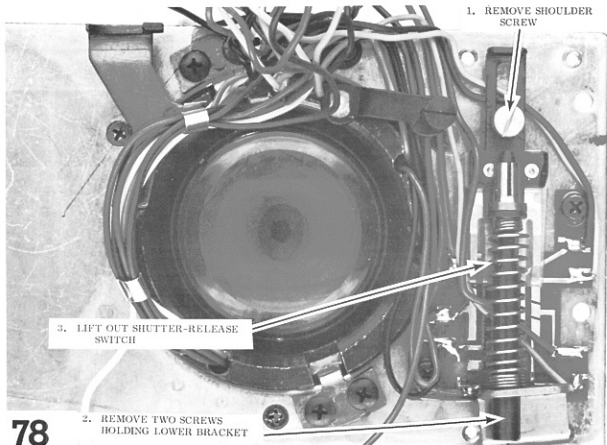

78

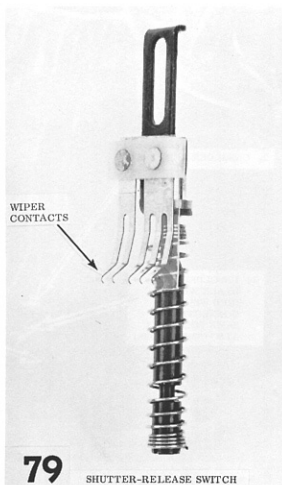

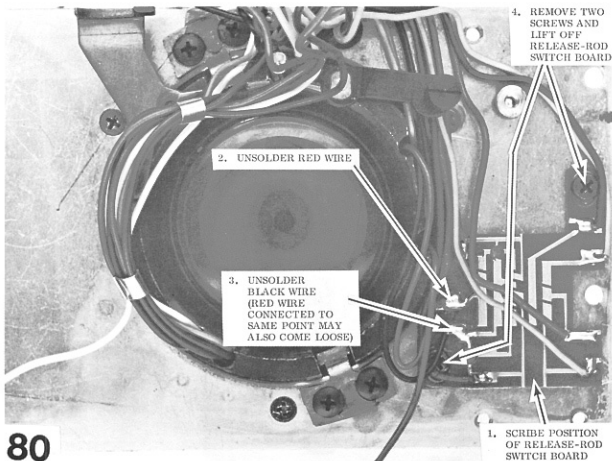

SWITCH BASE PLATES

OLD TYPE

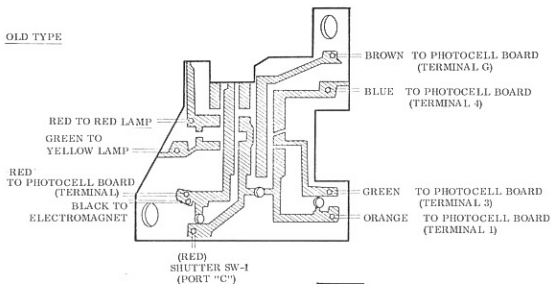

NEW TYPE

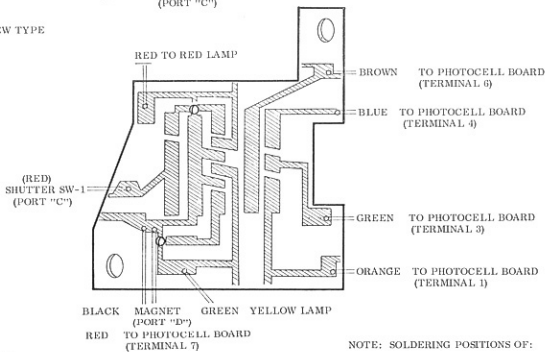

NOTE: SOLDERING POSITIONS OF:

- | | |
|----------|--------------|
| 1. GREEN | YELLOW LAMP |
| 2. RED | SHUTTER SW-1 |

SWITCH BASE PLATES

SWITCH POSITION FOR RED
LAMP INDICATION

OLD TYPE

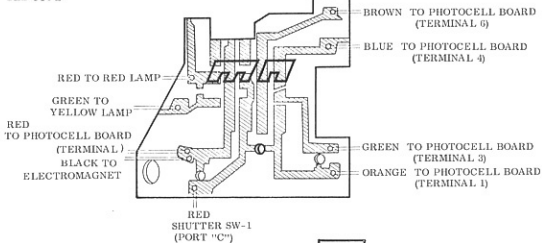

NEW TYPE

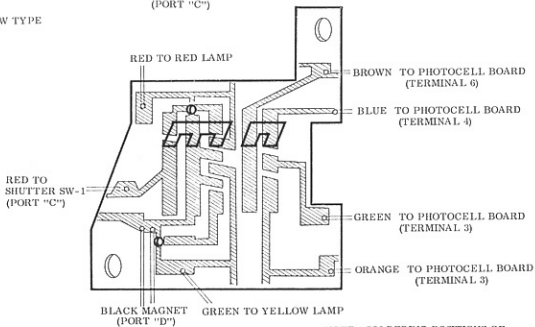

82

RED TO PHOTOCELL BOARD
(TERMINAL 7)

NOTE: SOLDERING POSITIONS OF:
1. GREEN YELLOW LAMP
2. RED SHUTTER SW-1

SWITCH BASE PLATES

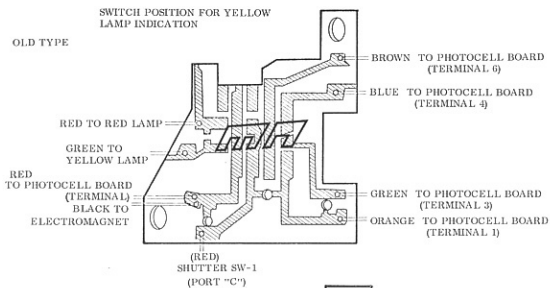

NEW TYPE

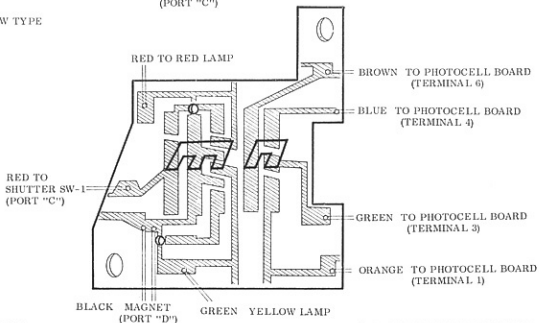

83

RED TO PHOTOCELL BOARD (TERMINAL 6)

NOTE: SOLDERING POSITIONS OF:
1. GREEN YELLOW LAMP
2. RED SHUTTER SW-1

SWITCH BASE PLATES

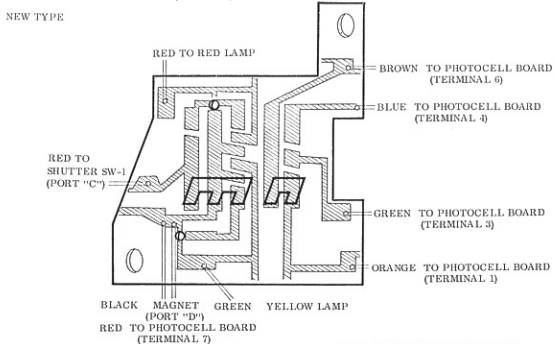
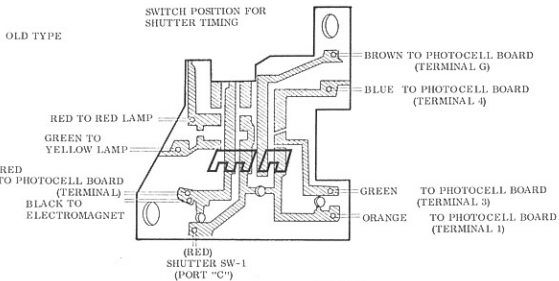

NOTE: SOLDERING POSITIONS OF:
1. GREEN YELLOW LAMP
2. RED SHUTTER SW-1



UNSOLDER
WHITE WIRE
FROM BATTERY-TEST
CIRCUIT BOARD

85

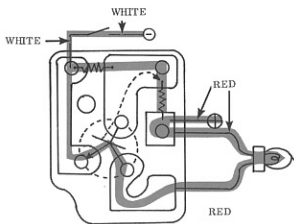

CHECKER BASE

86

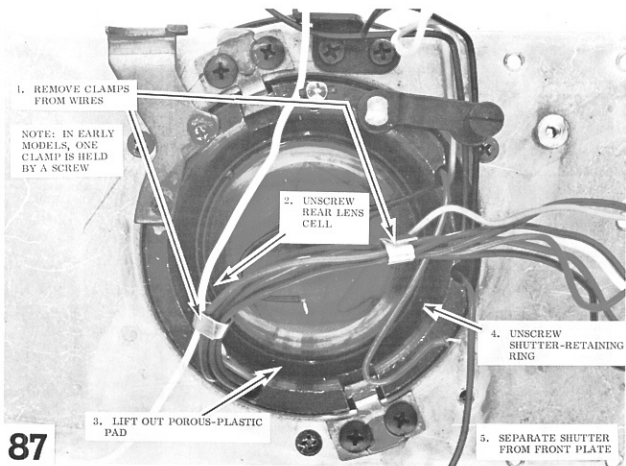

PORT A -- green, dark blue, orange, and brown

PORT B -- red, white, and purple

PORT C -- yellow, yellow, red, and black

PORT D -- red, black, and brown

(NOTE VARIATIONS IN YOUR PARTICULAR CAMERA)

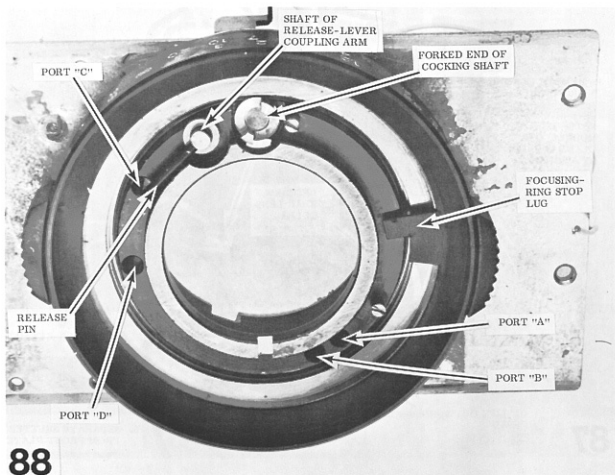

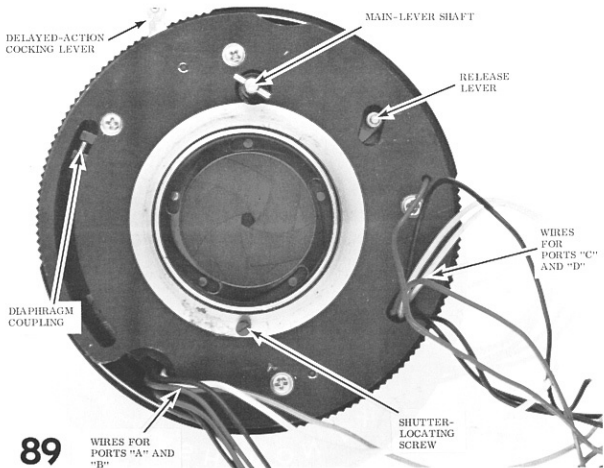

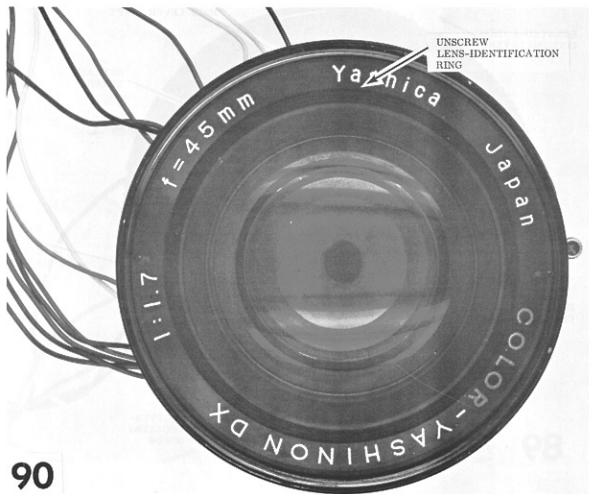

UNSCREW
LENS-IDENTIFICATION
RING

90

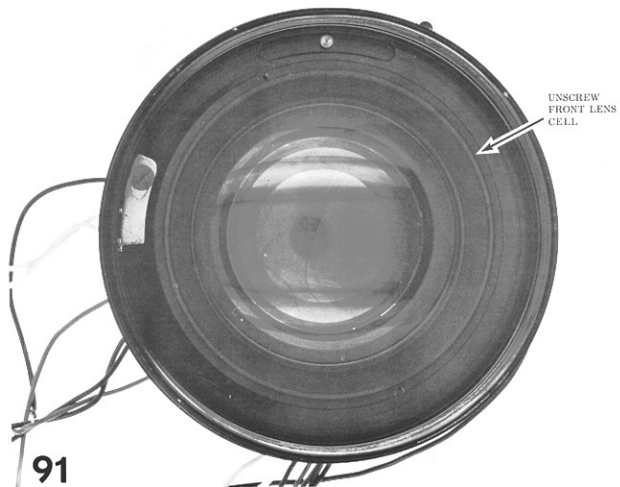

UNSCREW
FRONT LENS
CELL

91

REMOVE THREE SCREWS
AND LIFT OFF
SELECTOR-RING
ASSEMBLY

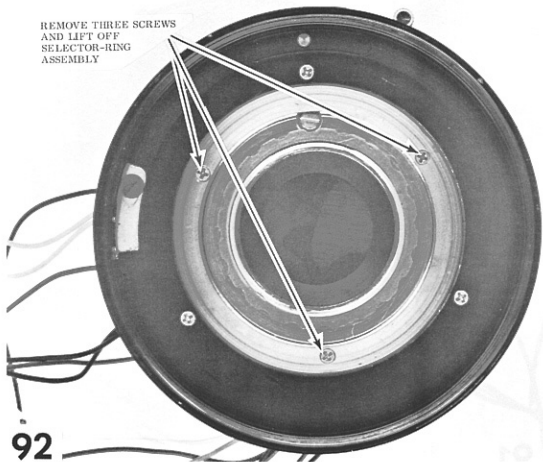

92

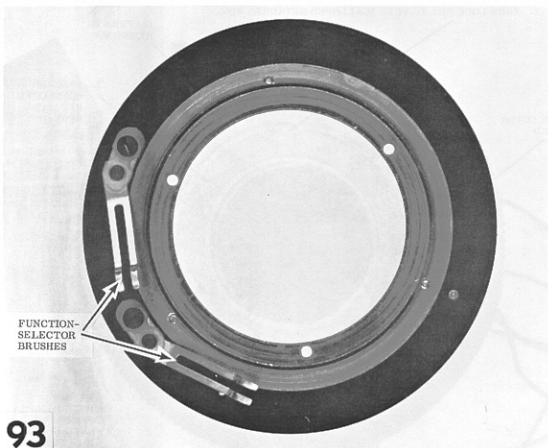

FUNCTION-
SELECTOR
BRUSHES

93

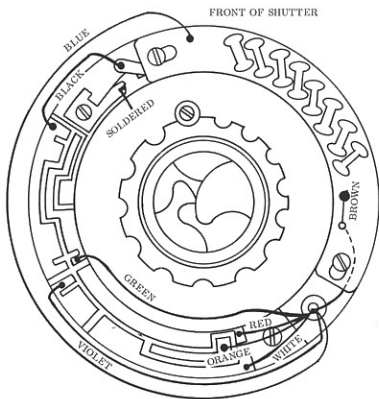
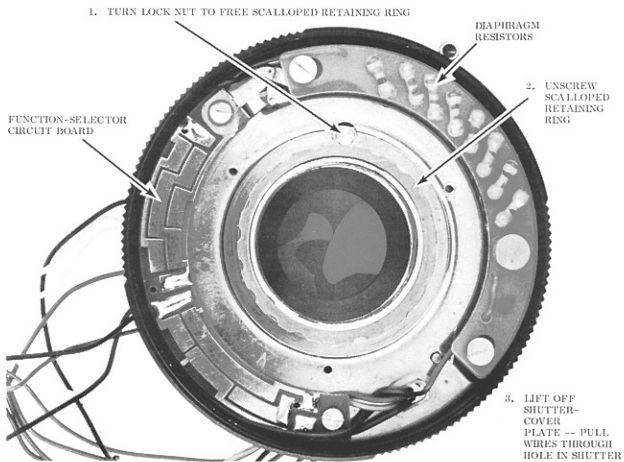

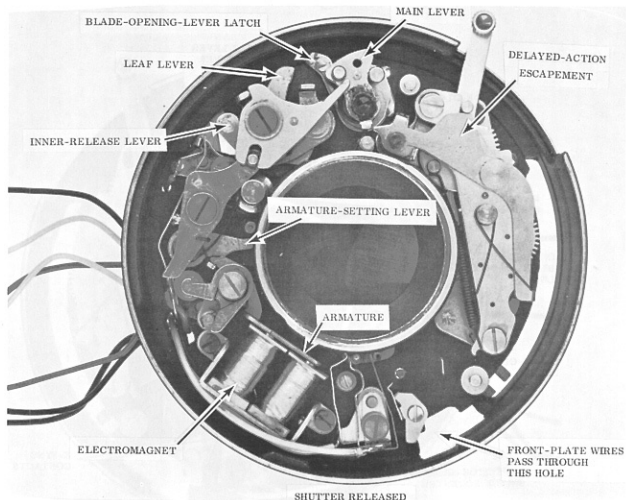

INSIDE SHUTTER

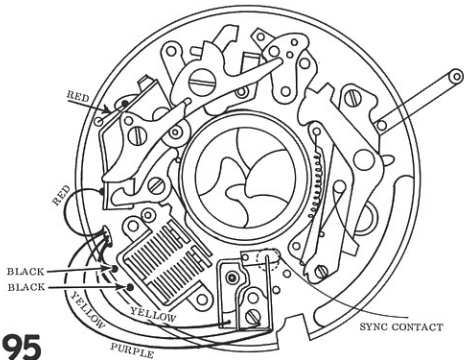

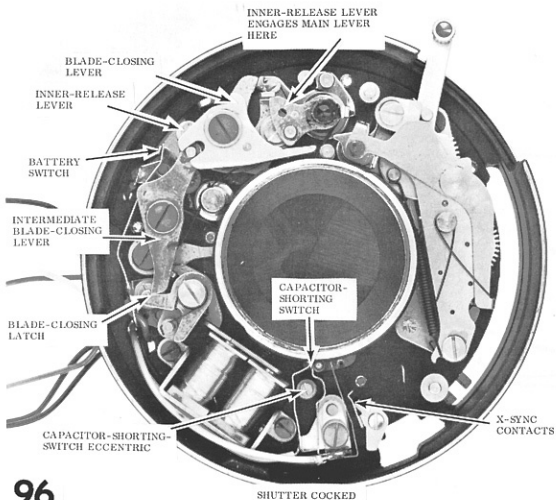

REMOVE SCREW
AND LIFT OUT
DELAYED-ACTION
ESCAPEMENT

NOTE: IN
SOME SHUTTERS,
THERE'S AN
ECCENTRIC
ADJUSTMENT
AT THIS
SCREW
POSITION

DELAYED-ACTION
COCKING LEVER
PASSES THROUGH
SLOT IN DUST
SEAL.

IN SOME
SHUTTERS,
THIS LOCATING
POST IS REPLACED
BY A SECOND
RETAINING SCREW

ASSEMBLY SEQUENCE OF SWITCH ASSEMBLY
(STARTING FROM MECHANISM PLATE):

1. KEYED INSULATOR, SHOULDER UP
2. MOVABLE X-SYNC CONTACT
3. INSULATOR
4. FIXED CAPACITOR-SHORTING-SWITCH BLADE
5. INSULATOR
6. MOVABLE CAPACITOR-SHORTING-SWITCH BLADE
7. ROUND INSULATOR
8. SCREW

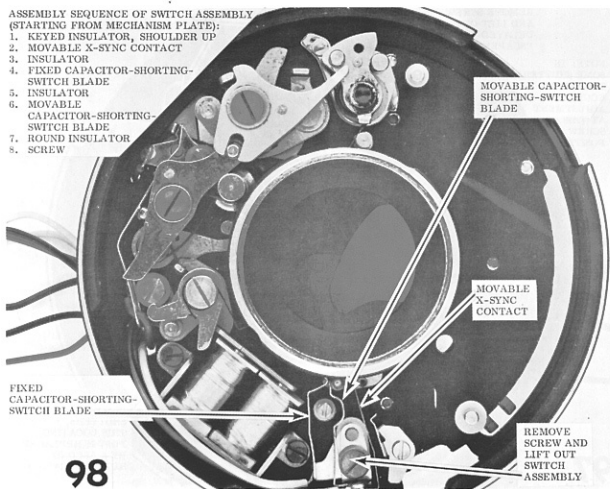

MOVABLE CAPACITOR-SHORTING-SWITCH BLADE

MOVABLE X-SYNC CONTACT

FIXED CAPACITOR-SHORTING-SWITCH BLADE

REMOVE SCREW AND LIFT OUT SWITCH ASSEMBLY

98

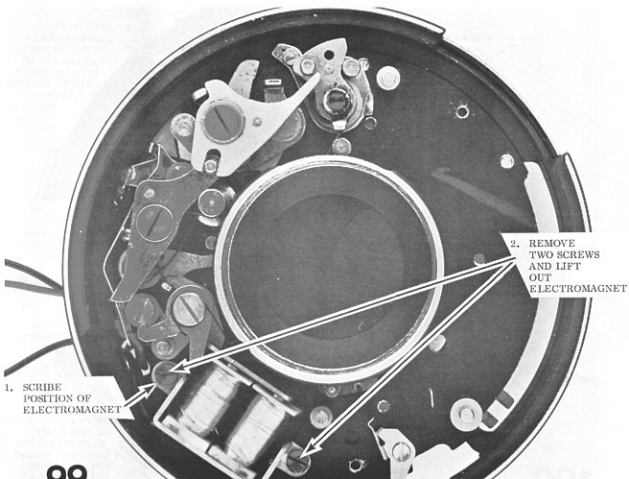

99

The resistance of the electromagnet should be within the range of 80 ohms to 120 ohms.

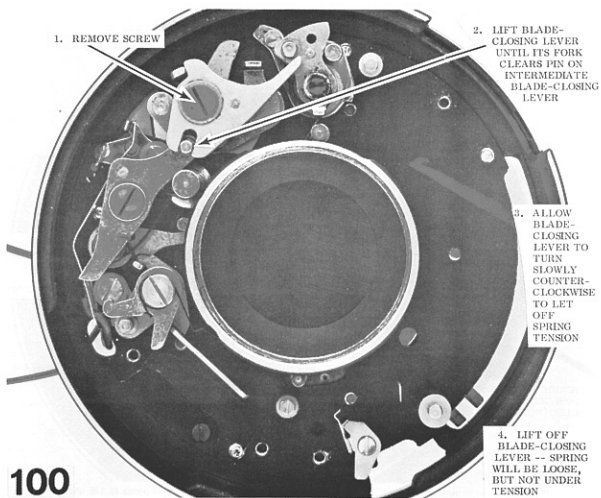

100

LIFT OUT
BLADE-CLOSING-LEVER
SPRING

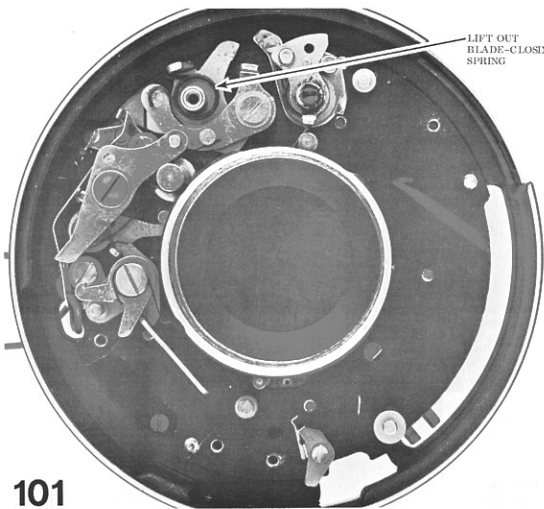

101

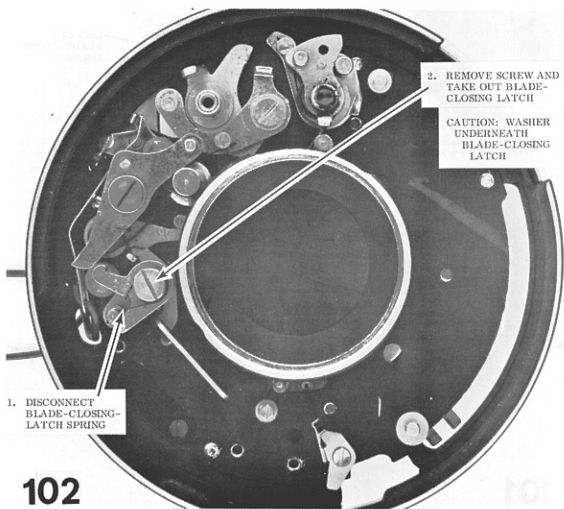

1. DISCONNECT
ARMATURE
SPRING FROM
ARMATURE-
SETTING
LEVER

2. LIFT OUT
ARMATURE
WITH ITS
SPRING

103



REMOVE SCREW HOLDING
INTERMEDIATE
BLADE-CLOSING
LEVER

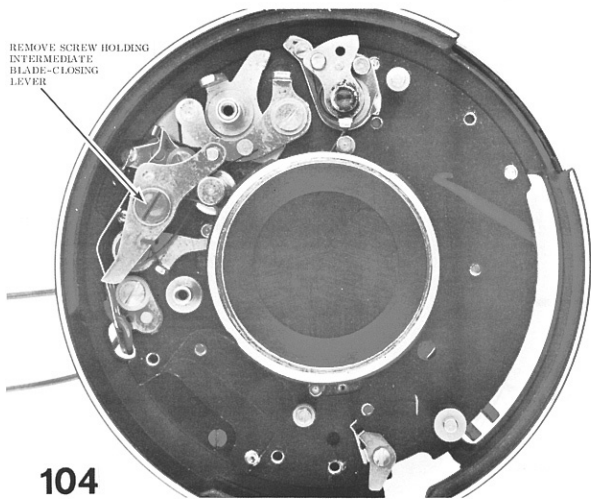

104

1. LIFT INTERMEDIATE
BLADE-CLOSING LEVER
AND ALLOW IT TO TURN
SLOWLY CLOCKWISE
UNTIL THE SPRING
COMPLETELY
UNWINDS

2. NOTE THAT END OF INTERMEDIATE-
BLADE-CLOSING-LEVER
SPRING HOOKS TO POST --
UNDERNEATH ARMATURE-
SETTING-LEVER SPRING

3. LIFT OUT
INTERMEDIATE
BLADE-CLOSING
LEVER
WITH ITS
SPRING

105



1. REMOVE SCREW
AND LIFT OUT
MOVABLE
BATTERY-SWITCH
CONTACT

2. REMOVE SCREW
AND LIFT OUT
FIXED
BATTERY-SWITCH
CONTACT

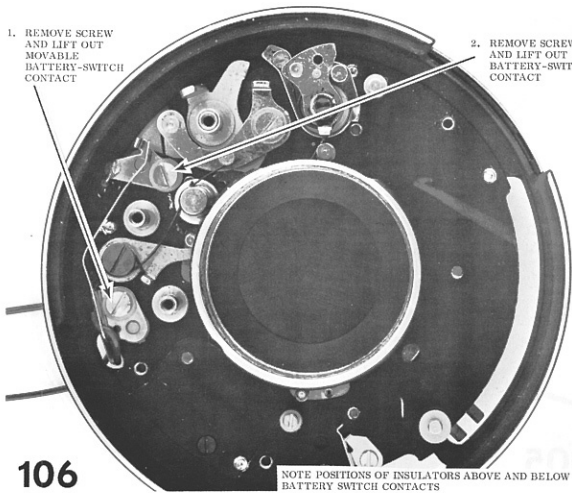

106

NOTE POSITIONS OF INSULATORS ABOVE AND BELOW
BATTERY SWITCH CONTACTS

1. LIFT OUT LOWER
BATTERY-SWITCH
INSULATORS

2. DISCONNECT
RELEASE-LEVER
SPRING

3. REMOVE SCREW
AND LIFT OUT
RELEASE LEVER

RELEASE-LEVER
SPRING CAN REMAIN
ON POST

107

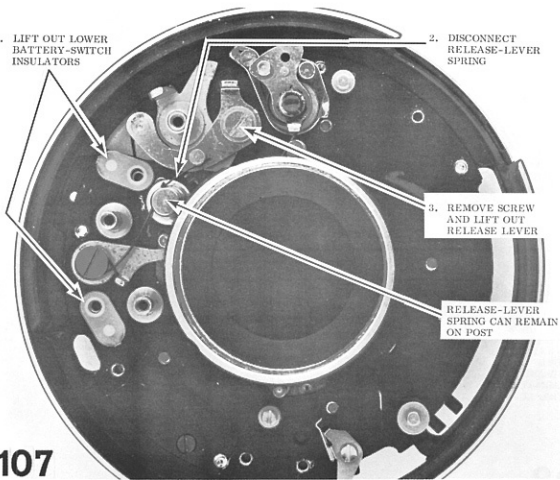

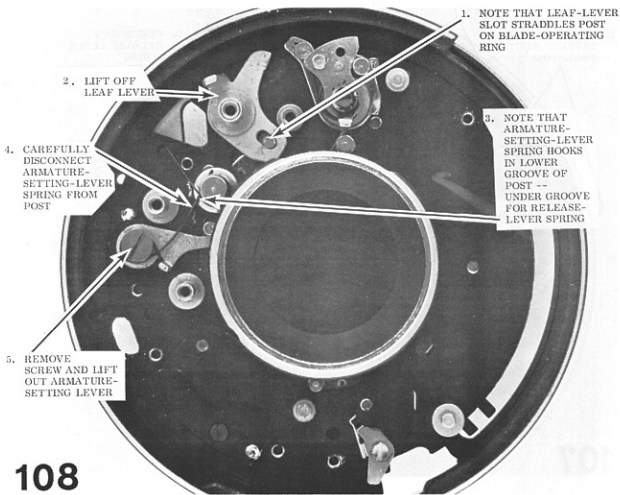

1. PRESS OUT
TAPERED COCKING
PIN IN
DIRECTION
INDICATED

2. REMOVE FOUR
SHUTTER-HOUSING
SCREWS

NOTE: SCREWS MAY BE DIFFERENT IN LENGTH

3. LIFT
SHUTTER
HOUSING
FROM
MECHANISM
PLATE

109

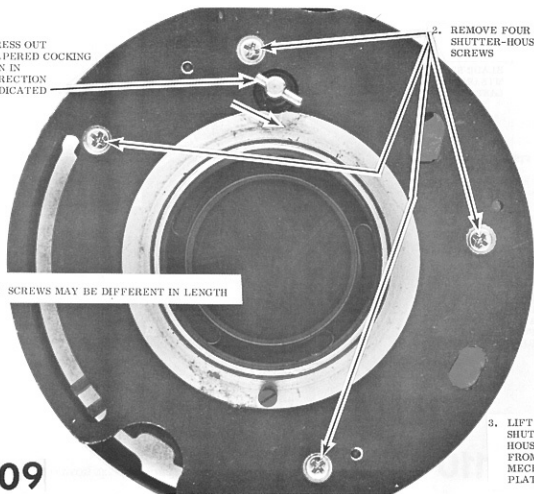

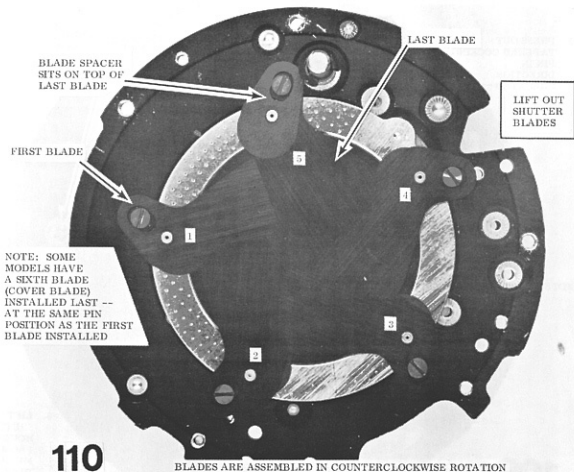

OTHER FOUR BLADE
SPACERS SIT
UNDERNEATH
SHUTTER BLADES

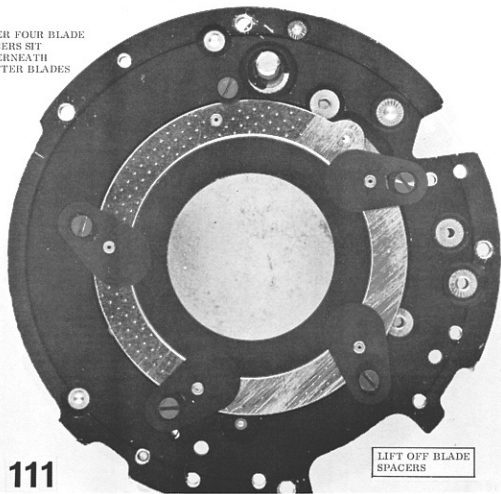

111

LIFT OFF BLADE
SPACERS

1. REMOVE FIVE SCREWS
HOLDING BLADE-OPERATING
RING --
NOTE WASHER
UNDER EACH
SCREW

2. LIFT OFF
BLADE-
OPERATING
RING

112

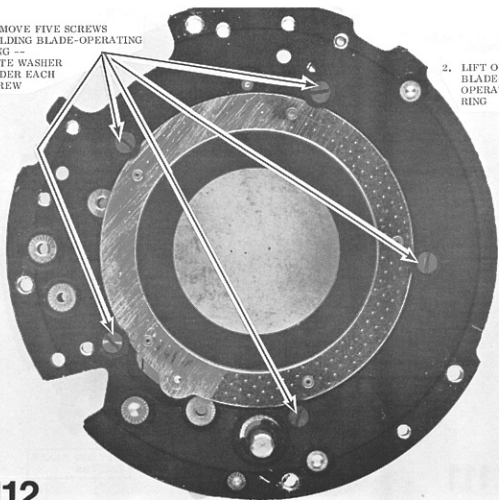

REMOVE E-RING (S)
FROM MAIN-LEVER
SHAFT

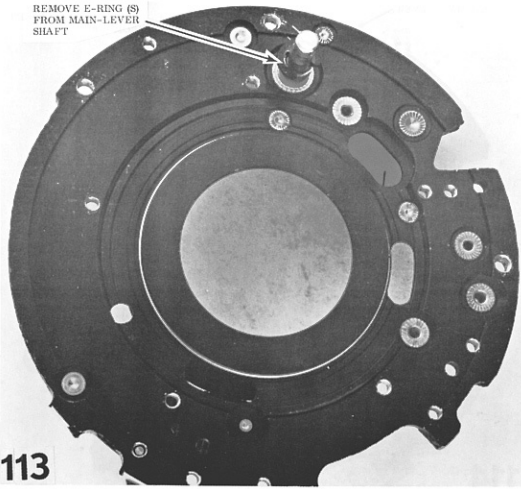

113

2. LIFT OUT MAIN LEVER

1. DISCONNECT MAINSPRING
FROM POST

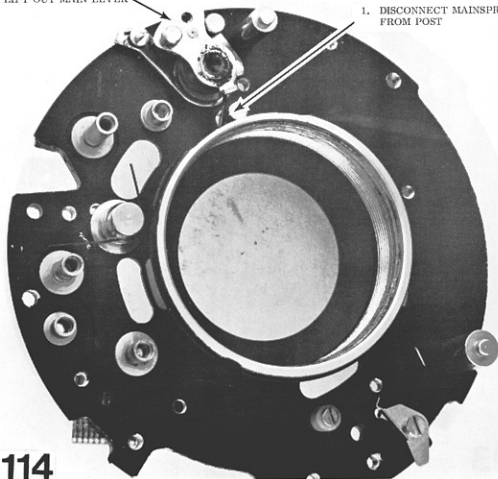

114

1. DISCONNECT BLADE-OPENING-LATCH
SPRING FROM POST

2. LIFT OUT BLADE-
OPENING LATCH --
SPRING REMAINS
ON LATCH

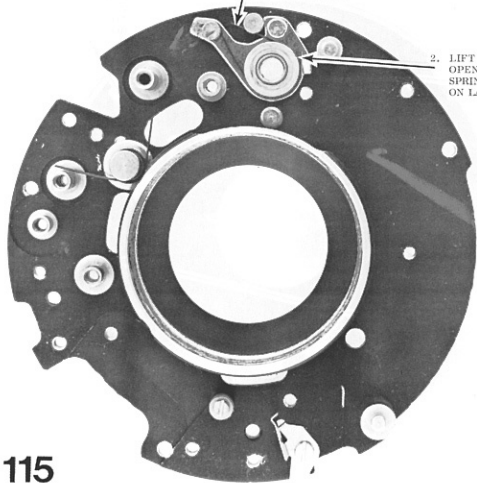

115

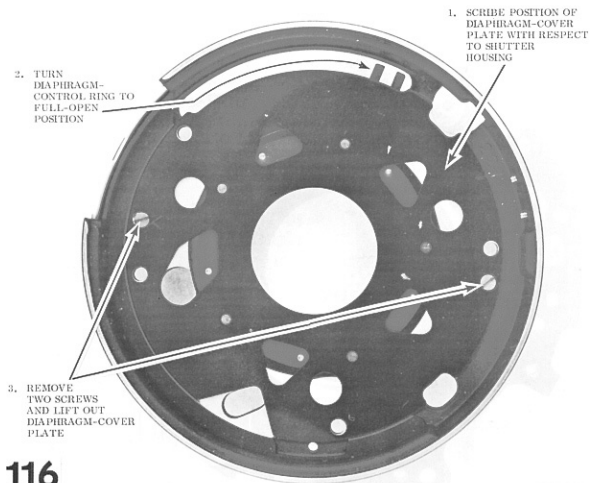

REMOVE FIVE DIAPHRAGM
LEAVES

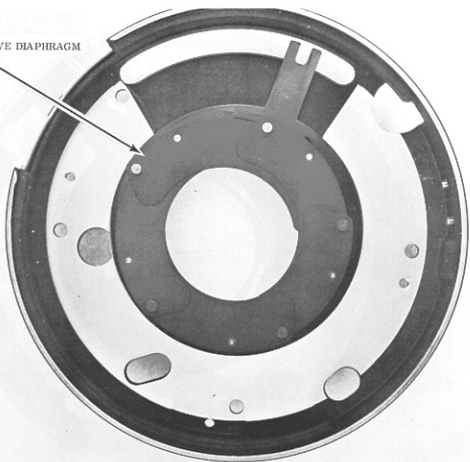

117

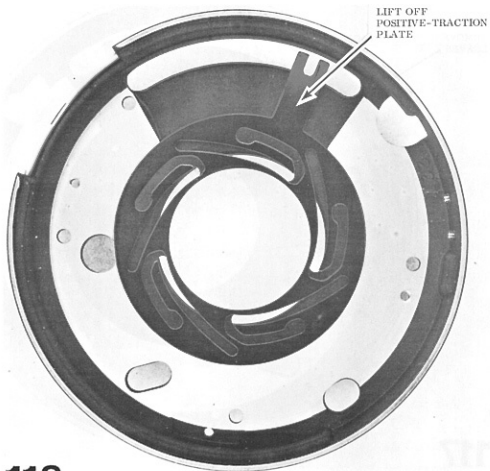

118

LIFT OUT
DIAPHRAGM-CONTROL
RING

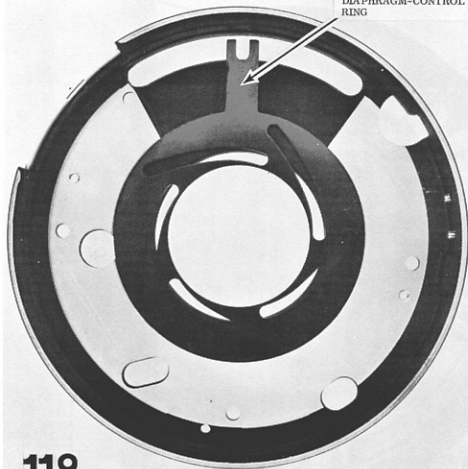

119

1. REMOVE TWO SCREWS AND LIFT OFF PLASTIC COVER

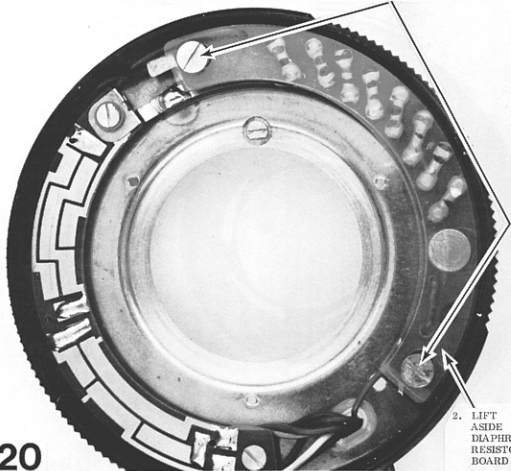

2. LIFT
ASIDE
DIAPHRAGM-
RESISTOR
BOARD

120

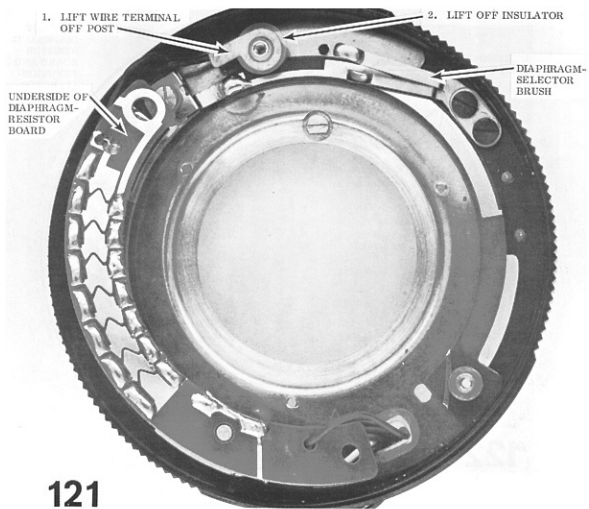

1. REMOVE TWO
SCREWS

2. LIFT OUT
DIAPHRAGM-
RESISTOR
BOARD AND
FUNCTION-
SELECTOR
BOARD

122



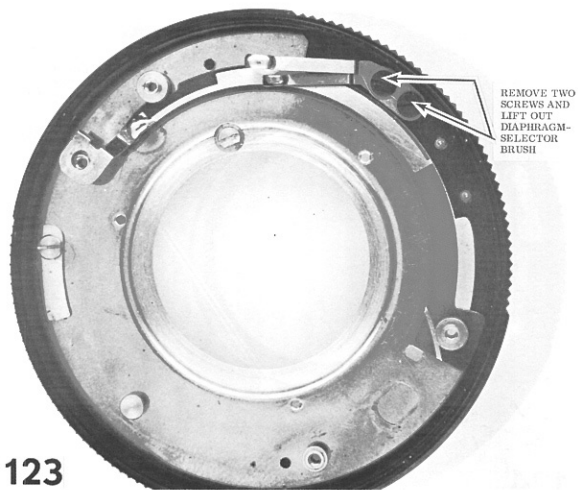

REMOVE TWO
SCREWS AND
LIFT OUT
DIAPHRAGM-
SELECTOR
BRUSH

123

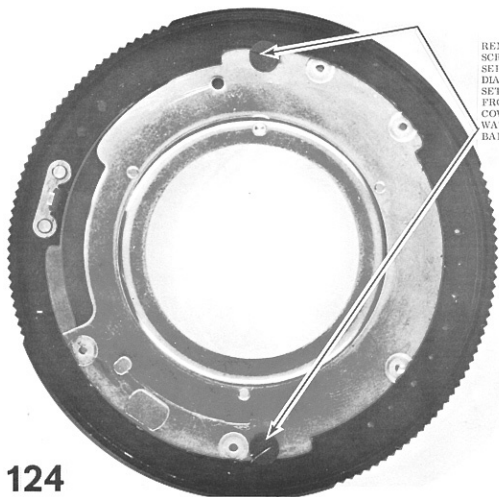

REMOVE TWO
SCREWS TO
SEPARATE
DIAPHRAGM-
SETTING RING
FROM SHUTTER-
COVER PLATE --
WATCH FOR
BALL DETENT

124